



equinox[®]
SHOULDER SYSTEM



Reverse Shoulder System



ANATOMICAL.
REDEFINED.

TABLE OF CONTENTS

INTRODUCTION	1
PRODUCT HIGHLIGHTS	2
SYSTEM SPECIFICATIONS	3
OVERVIEW TECHNIQUE	4
DETAILED OPERATIVE TECHNIQUE	7
INDICATIONS	7
CONTRAINDICATIONS	7
PRE-OPERATIVE PLANNING	7
Patient Positioning	7
Deltopectoral Approach.....	8
Superior-Lateral Approach	8
Humeral Preparation	9
Humeral Head Resection.....	9
Reaming the Humeral Shaft.....	10
Broaching the Humeral Shaft	10
Inserting the Humeral Stem Trial	11
Humeral Stem Protector	11
Preparing the Glenoid	12
Glenoid Exposure	12
Drilling Pilot Hole for Glenoid Reamer	13
Reaming the Glenoid.....	13
Drill Cage Hole through Drill Guide	13
Bone Graft for Glenoid Plate.....	14
Implanting the Glenoid Plate	14
Inserting the Glenosphere Trial	15
Trialing the Humeral Adapter Tray and Liner	16
INSERTING THE FINAL IMPLANTS	18
Deltopectoral Closure.....	19
Superior-Lateral Closure.....	19
Glenosphere Removal.....	20
Post-Operative Rehabilitation	20
EQUINOXE IMPLANT SCOPE	21
EQUINOXE REVERSE INSTRUMENT SCOPE	22



EQUINOXE® SHOULDER SYSTEM DESIGN TEAM

Lynn A. Crosby, MD

Wright State University

Pierre-Henri Flurin, MD

Surgical Clinic of Bordeaux, Merignac (France)

Thomas W. Wright, MD

University of Florida

Joseph D. Zuckerman, MD

NYU Hospital for Joint Diseases

The Equinox® Shoulder System redefines “anatomical.” The primary stem allows independent adjustability of all four anatomic parameters *in situ*. The reverse shoulder is an optimized design that minimizes both scapular notching and torque on the glenoid while seamlessly integrating with the primary stem. The fracture stem’s offset anterior-lateral fin and asymmetric tuberosity beds define the next generation in complex fracture reconstruction.

INTRODUCTION

Thank you for considering the Equinox Reverse Shoulder System. The challenges and complications surgeons have thus far experienced with reverse shoulders have been well documented and led our team to begin development of a prosthesis that seeks to address those challenges. In general, we sought the following improvements:

Optimized Design. The glenoid and humeral reverse components are designed to maintain the center of rotation just off the face of the glenoid (to reduce torque on the glenoid), restore anatomic tension of the remaining intact rotator cuff muscles and deltoid (to improve function), and minimize scapular notching by distally shifting the glenosphere.

Maximized ROM. Computer analyses have predicted that the Equinox reverse shoulder provides as much as 50 percent increase in ROM over the Grammont design before scapular contact or notching.^{1,2}

Improved Stability. Larger diameter glenospheres provide a larger arc of motion, greater resistance to dislocation, and better tensioning of the intact rotator cuff muscles.^{1,2}

Bone Conservation. The humeral reverse components do not require reaming of the proximal humerus. An additional advantage of this is that the size of the glenosphere is no longer limited by the corresponding humeral cup size that will fit in the proximal humerus.

Anatomical. Redefined. The glenospheres and glenoid plate are anatomically shaped to increase the number of screw holes available for fixation and improve their positioning relative to glenoid bone depth/quality. Independent testing has demonstrated excellent glenoid fixation can be achieved (micromotion of <70 microns).³ The multi-axial screws provide compression and lock to provide optimum bone purchase, compression of the glenoid plate and stability of the locked screw.

Reversatility. The Equinox reverse components build off the existing Equinox primary humeral stems, which enables surgeons to use the same (i.e. traditional) surgical technique/humeral osteotomy, and most importantly, to convert a well-fixed Equinox stem to a reverse **without stem removal**.

We hope you come to agree, based on your experiences with the Equinox Reverse Shoulder in the O.R., that we have accomplished our goals.

Finally, we would be remiss if we failed to make it clear that reverse shoulders are challenging procedures and should be performed by surgeons with significant reverse experience. If you are new to reverse shoulders, please consider observing a shoulder specialist, watching a reverse surgical DVD, performing a reverse sawbone and/or implanting a reverse in a cadaver to ensure you are comfortable with the surgical technique. We would be happy to facilitate any aspect of this training.

Respectfully,

Lynn A. Crosby, MD
Pierre-Henri Flurin, MD
Thomas W. Wright, MD
Joseph D. Zuckerman, MD

PRODUCT HIGHLIGHTS



- 1** Inferiorly Shifted Glenoid Plate – allows fixation to occur in the center of the glenoid while also ensuring inferior glenosphere overhang, thereby, eliminating/minimizing scapular notching
- 2** Bone Cage – improves glenoid fixation and allows bone ‘through-growth’
- 3** Chamfered Glenosphere – aids in glenosphere insertion and protects any remaining intact soft tissues
- 4** Extended Glenosphere Articular Surface – improves range of motion and maximizes glenosphere inferior overhang to minimize the potential for scapular notching
- 5** Multiple Humeral Liner (standard and constrained), Adapter Tray, and Glenosphere Options - provides intra-operative flexibility
- 6** Curved Back Glenosphere/Glenoid Plate – conserves bone and converts shear forces to compressive forces

- 7** Anatomical Shaped Glenoid Plate – provides multiple options for screw insertion, which is particularly important when revising a pegged and/or keeled glenoid to a reverse
- 8** Variable Angle Compression Screws – compresses the glenoid plate to the bone while providing 30 degrees of angular variability (Note: the central cage of the glenoid plate limits the angular variability to 20 degrees for converging anterior, posterior and superior screws.)
- 9** Anti-Rotation Features on Humeral Liners and Trays – improves implant connection and stability
- 10** Platform Humeral Stem – facilitates a revision of a primary Equinox humeral stem to a reverse
 - Locking Caps – locks compression screws to the glenoid plate at a variable angle (not pictured)
 - Torque Defining Screw – locks the humeral adapter tray at 11 N*m (not pictured)

SYSTEM SPECIFICATIONS (All dimensions in millimeters)

Humeral Stem

Distal Diameter	Length*	Inherent Medial Offset	Material	Surface Finish		Geometry	
				Proximal	Distal	Proximal	Distal
7	100	7.5	Ti-6Al-4V	16 grade grit blast	Hi-Brite Polish	Trapezoidal	Cylindrical with flutes
9	105						
11	110	8.5					
13	115						
15	120	9.5					
17	125						

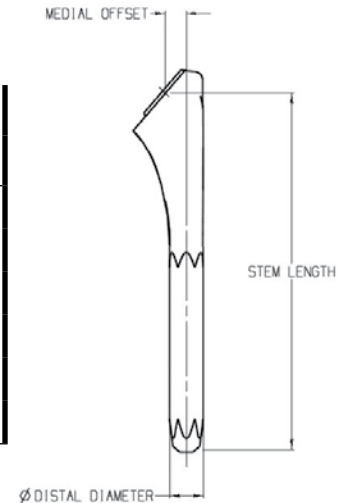

* Measured from distal tip to center of proximal spherical bore

Humeral Liner/Humeral Tray Offset Comparisons

	+0mm Humeral Liners (Standard and Constrained)	+2.5mm Humeral Liners (Standard and Constrained)
+0 Humeral Tray	0	2.5
+5 Humeral Tray	5	7.5
+10 Humeral Tray	10	12.5
+15 Humeral Tray*	15	17.5

* special order

Humeral Liner Depth Comparisons

	Standard Liner Depth (+0mm and +2.5mm)	Constrained Liner Depth (+0mm and +2.5mm)
38 Humeral Liners	8.5	12.0
42 Humeral Liners	8.8	12.6
46 Humeral Liners*	8.9	13.1

* special order

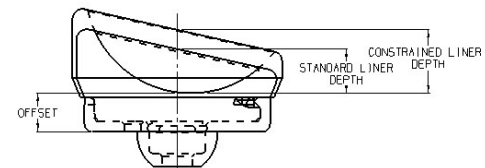

Compression Screws

Diameter	Length	Color
4.5	18	White
	22	Black
	26	Orange
	30	Blue
	34	Red
	38	Green
	42	Yellow
	46	Purple

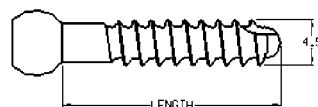

Glenosphere/Glenoid Plate

	Diameter	Thickness	Lateralization of Center of Rotation
38 Glenosphere	38	23.1	3.6
42 Glenosphere	42	25.1	
46 Glenosphere*	46	27.1	4.1

* special order

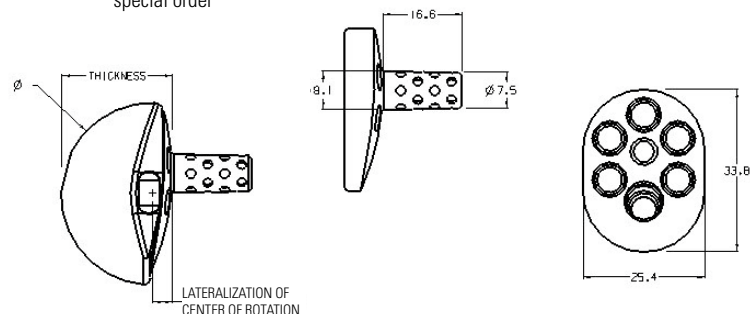

OVERVIEW TECHNIQUE



A Resecting humeral head



B Reaming the humeral shaft



C Broaching the humeral shaft



D Inserting the humeral stem trial



E Inserting stem protector

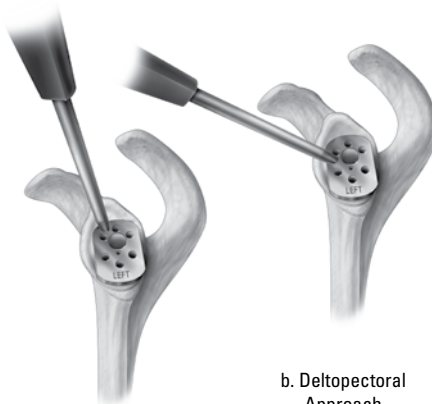

a. Superior-Lateral Approach

b. Deltopectoral Approach

F Aligning drill guide

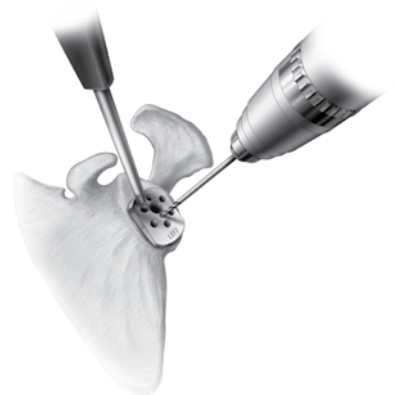

G Drilling reamer pilot hole

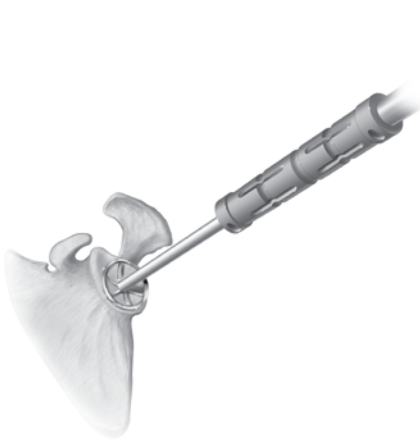

H Reaming the glenoid

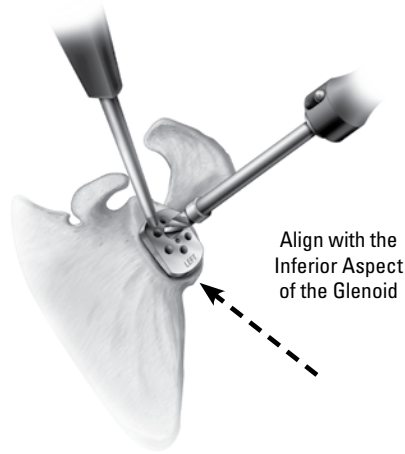

I Drilling glenoid plate hole



J Inserting glenoid plate

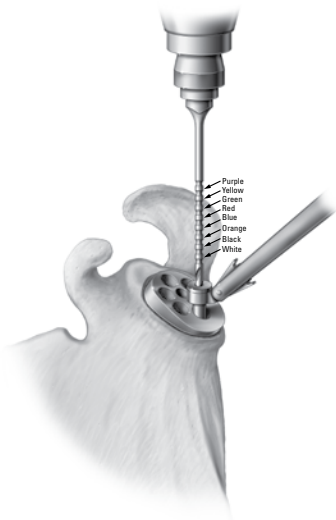

K Drilling for and implanting compression screws



L Tightening locking caps

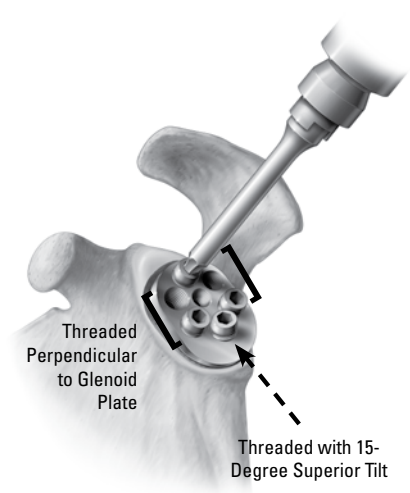

M Inserting glenosphere trial

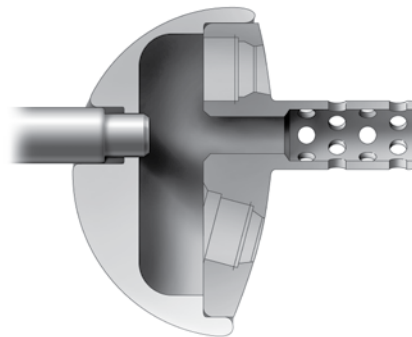
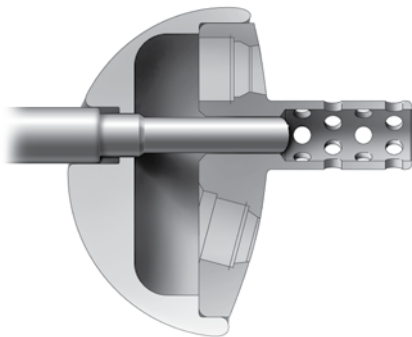



N Inserting humeral tray trial and liner trial



O Removing liner trial



P Inserting definitive glenosphere



Q Cementing definitive stem



R Implanting definitive tray



S Implanting definitive liner

DETAILED OPERATIVE TECHNIQUE

Rotator cuff arthropathy is characterized by glenohumeral arthritis in the presence of a massive and irreparable rotator cuff defect.

INDICATIONS

Use of the Equinox Reverse Shoulder System is indicated in the following situations:

- Rheumatoid arthritis, osteoarthritis, osteonecrosis, or post-traumatic degenerative problems in conjunction with an irreparable or nonfunctional rotator cuff and/or a superiorly migrated humerus
- Pathologies where arthrodesis or resectional arthroplasty of the humeral head are not acceptable
- Revisions of humeral prostheses when other treatments or devices have failed (where adequate fixation can be achieved)
- Revisions of failed previous reconstructions when distal anchorage is required
- Revisions of failed previous reconstructions when distal anchorage is not required
- To restore mobility from previous procedures (e.g. previous fusion).

CONTRAINDICATIONS

Use of the Equinox Reverse Shoulder System is contraindicated in the following situations:

- Osteomyelitis of the proximal humerus or scapula; if a systemic infection or a secondary remote infection is suspected or confirmed, implementation should be delayed until infection is resolved.
- Inadequate or malformed bone that precludes adequate support or fixation of the prosthesis
- Neuromuscular disorders that do not allow control of the joint
- Significant injury to the brachial plexus
- Non-functional deltoid muscle
- Patient's age, weight or activity level would cause the surgeon to expect early failure of the system
- The patient is unwilling or unable to comply with the post-operative care instructions
- Alcohol, drug or other substance abuse
- Any disease state that could adversely affect the function or longevity of the implant.

PRE-OPERATIVE PLANNING

After a careful history and physical examination, radiographs should be obtained to assess glenohumeral joint space narrowing, osseous deformities and glenoid wear. A CT scan is helpful to assist in the evaluation of the quality of bone stock and to further evaluate bone deformities that may be present. An MRI may be obtained if further evaluation of the soft tissues is determined to be helpful. To aid in pre-operative planning, radiographic templates are provided for the humeral components and glenoid components to approximate the required size and alignment of the implants.

Step 1: Patient Positioning

The patient should be placed on an operating table in a supine position. The head of the operating table should be elevated approximately 30 degrees in a modified beach chair position. A small bolster should be placed laterally behind the involved shoulder. The patient should be moved to the side of the table so that the upper extremity can be placed in maximum extension without obstruction by the operating table. Alternatively, a Captain's chair or similar positioning device can be used for proper patient positioning. The patient should be secured to the operating table to minimize any changes in position intra-operatively. The entire upper extremity should be prepped and draped to allow complete access to the operative area and full mobility during the procedure. Either a deltopectoral or a superior-lateral approach may be used depending on the surgeon's preference and clinical parameters.

Step 2a: Deltopectoral Approach

An anterior deltopectoral incision is made beginning inferior to the lateral clavicle, passing over the coracoid process and extending distally toward the deltoid insertion. Medial and lateral subcutaneous flaps are created, and the deltopectoral interval is identified.

A thin fat stripe is often located over the cephalic vein. The interval is usually developed medial to the cephalic vein; the interval can also be developed laterally depending on the surgeon's preference. Branches of the cephalic vein on the approach side are cauterized, and the interval is developed inferior to superior to expose the clavipectoral fascia.

The advantage of retracting the cephalic vein with the deltoid is that the majority of the branches enter from the deltoid. The disadvantage is the vein is more exposed to injury from the retractor as it crosses the superior aspect of the interval.

The subdeltoid space is mobilized with a blunt elevator. The clavipectoral fascia is incised longitudinally up to the coracoacromial ligament (which is spared), and the conjoined tendon is mobilized. A self-retaining retractor is placed with care to avoid excessive traction on the conjoined tendon. The coracoacromial ligament is identified and the subacromial space is mobilized with a blunt elevator. The subscapularis tendon insertion (if present) on the lesser tuberosity is identified along with the rotator interval. The anterior humeral circumflex vessels along the inferior border of the subscapularis muscle (the "three sisters") are cauterized extensively. The axillary nerve should be palpated in its position at the inferomedial border of the subscapularis. Exposure of the nerve for direct visualization can be performed at this point based upon surgeon preference. The biceps tendon (if present) is palpated in its groove. A biceps tenodesis can be performed at this point by dividing the tendon in the mid-portion of the groove and securing it either to the adjacent soft tissues or to bone based upon surgeon preference. The subscapularis tendon and the capsule are tenotomized 1cm medial to the lesser tuberosity and tagged with #1 sutures. The inferior capsule should be released from the humeral neck to allow the humerus to be externally rotated 90

degrees. As this release is performed, the axillary nerve should be protected by placing a blunt elevator between it and the inferior capsule.

An alternative approach is to elevate the subscapularis directly off the bone or elevate its insertion with a thin wafer of bone (1-2mm thick) using an osteotome. The choice of subscapularis detachment and subsequent reattachment is based primarily on surgeon preference. In some cases, particularly with revision surgery, the subscapularis may be absent or only the inferior portion may remain.

Exposure of the subacromial space will reveal a massive rotator cuff defect. Often there is an extensive amount of fibrous and bursal tissue filling this area that should be excised. The humerus can then be placed in extension, adduction and external rotation to begin preparation of the humerus. The large deltoid retractor should be used to enhance exposure of the proximal humerus.

Step 2b: Superior-Lateral Approach

A superolateral incision is made beginning at the anterior edge of the acromion and directed posterolaterally in an oblique direction. Subcutaneous dissection is performed to raise generous flaps medially and laterally. The interval between the anterior and middle portions of the deltoid is identified and this interval is developed superiorly over the top of the acromion. In doing so, the anterior deltoid is detached from its acromial attachment along with the coracoacromial ligament insertion. The interval is developed up to 4cm distally from the acromion to avoid potential injury to the axillary nerve. This provides exposure of the subacromial space, which is usually filled with fibrous and bursal tissue that should be removed to expose the humeral head. Any remaining intact rotator cuff should be visualized and usually includes a portion of the subscapularis and teres minor, although one or both may be absent.

The humerus should be placed in extension, adduction and external rotation along with superior displacement to dislocate the humeral head anterosuperiorly for exposure. Once again, the large Deltoid Retractor can be used to enhance visualization and exposure of the proximal humerus.



Figure 1
Humerus



Figure 2
Anatomic Cutting Guide



Figure 3
Fixed Angle Cutting Guide

Step 3: Humeral Preparation

Humeral Head Resection

Prior to humeral head resection, all osteophytes should be removed using a Rongeur (*Figure 1*). Doing so will properly allow identification and exposure of the anatomic humeral neck. An aggressive resection at or just distal to the anatomic neck is recommended. Care should be taken not to make a resection with more than 20 degrees of retroversion as this will limit internal rotation.

Anatomic Cutting Guide: The Equinoxe **Anatomic Cutting Guide** enables the surgeon to accurately resect the humeral head along, or just distal to, the anatomic neck without the use of complicated intra- or extra-medullary alignment guides or cutting guides. The jaws of the cutting guide should be placed at or just distal to the anatomic neck and used as a cutting surface for the resection.

The resection should proceed from inferior to superior. The smaller jaw of the guide should be placed along the sulcus adjacent to the greater tuberosity superiorly. The wide jaw should be in direct contact with the medial and inferior portion of the anatomic neck. Alternatively, an anterior-posterior cutting approach can be used with the thin jaw encircling the posterior side of the anatomic neck and the cutting jaw positioned anteriorly (*Figure 2*). Once the guide is in position, it is secured using the threaded knob. To ensure the cutting guide does not change position, the handle should be gripped while the osteotomy is performed; alternatively, two small K-wires (0.062 inches) can be inserted through the cannulated portions of the wider jaw.

Note: Removing the osteophytes is suggested in order to visualize the anatomic neck, but it also improves the bite obtained by the teeth on the cutting guide.

Free Hand: The anatomic neck is identified and the head is resected using a microsagittal saw at or just distal to the anatomic neck.

Fixed Angle (132.5 degrees) Cutting Guide: Three options are available for the **Fixed Angle Cutting Guide** (*Figure 3*): 1) Using the cutting surface to mark the resection line with a bovie and then use the free hand method; 2) Attaching the guide to a handle, which aligns with the forearm to provide 20 degrees of retroversion; and 3) Using K-wires to secure it to the proximal humerus. The Fixed Angle Cutting Guide is not used from the superior approach.

Once the head is resected, the surgeon can either proceed directly to the glenoid or continue to prepare the humerus. The latter allows the stem protector to be used to minimize damage to the proximal humerus while exposing the glenoid.

Reaming the Humeral Shaft

The smallest Reamer (7mm) has a sharp tip to facilitate the initial entry into the IM canal (*Figure 4*). The entry point is made just posterior to the bicipital groove and at the junction of the middle and upper thirds of the resected humeral surface. The canal should be sequentially reamed until endosteal cortical contact is obtained. It is imperative that the Reamer be inserted into the canal to the appropriate depth as indicated by the depth markers; **reaming prepares the canal for the distal diameter of the stem and determines the final diameter of the definitive stem**. There is no need for forceful reaming. If there is difficulty fully inserting a reamer, the broach and implant selected should be the size of the last reamer that was completely seated. If there is any concern about the size of the implant to use, the smaller alternative should be selected since the stem will be cemented in place.

Note: To ensure the adequate depth is achieved, ream until the depth marker is no longer visible.

Broaching the Humeral Shaft

After the canal has been reamed, the smallest Broach (7mm) is attached to the Broach Handle (*Figure 5*). The Broach should be inserted into the canal at a version consistent with that of the canal surface (i.e. the broach collar should be flush with the resected surface). The canal should be sequentially broached until the size of the Broach matches that of the final Reamer. Each Broach should be impacted until contact is made between the metaphyseal surface and the broach collar. The Broach should not be countersunk and only the strike surface should be used for impaction.

As a visual check to assess version, the Retroversion Handle can be attached to the Broach Handle ("L" and "R" indicate appropriate side) and aligned with the patient's forearm (assuming the patient has a stable elbow). The Retroversion Handle, when aligned with the forearm, indicates 20 degrees of retroversion. Care should be taken not to broach in more than 20 degrees of retroversion as this will limit internal rotation.

Note: The Broach is securely locked to the Broach Handle when the latch is returned to the starting position.

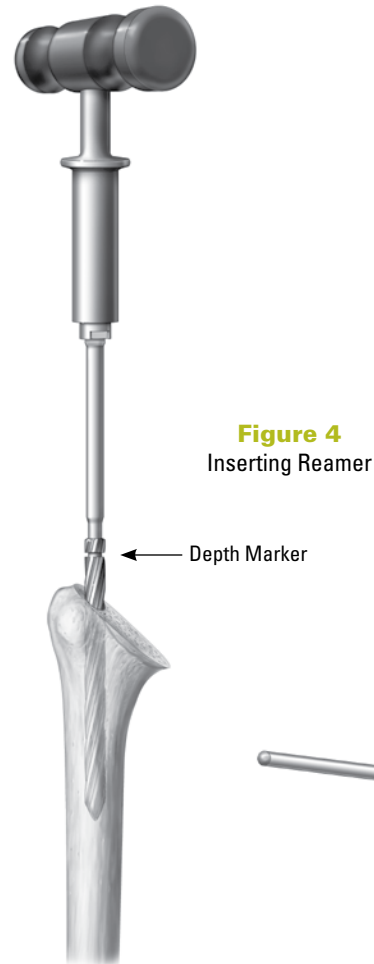

Figure 4
Inserting Reamer

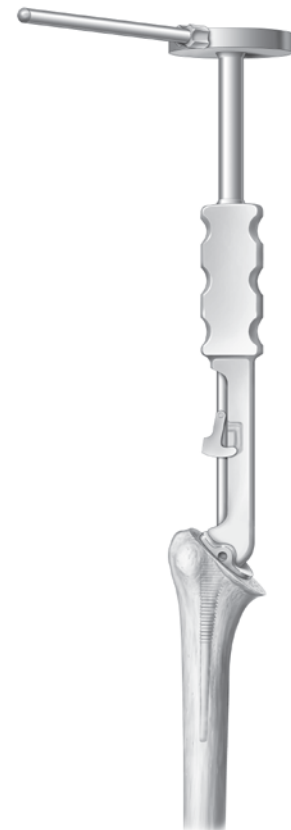

Figure 5
Inserting Broach



Figure 6
Inserting Stem Trial



Figure 7
Implanted Stem Trial



Figure 8
Stem Protector

Inserting the Humeral Stem Trial

The trial humeral stem size is determined by the largest Reamer that was fully inserted to the appropriate depth (*Figure 6*). The Humeral Stem Trial is attached to the Stem Inserter and impacted until it is fully seated in the humerus (*Figure 7*). **The trial is sized line-to-line with the Broach and Reamer. It is important to note that the reverse humeral component is intended to be used in either cemented applications or with an uncemented Equinox stem in revision cases when the component is well-fixed and stable, as determined by the orthopaedic surgeon's clinical and radiographic assessment.**

Humeral Stem Protector

The humeral **Stem Protector** should be placed into the proximal portion of the implanted stem to protect the resected surface during glenoid preparation (*Figure 8*).

Note: *The Stem Protector is offset so it can be rotated to ensure the best possible coverage.*

Step 4: Preparing the Glenoid

Glenoid Exposure

Retractors are provided to aid in glenoid exposure. A Posterior Glenoid Retractor (e.g. Wolfe Retractor) should be used to displace the proximal humerus posteriorly. A single- or double-spiked glenoid retractor is then placed anteriorly along the glenoid neck. Hohmann Retractors are placed superiorly and inferiorly around the glenoid.

The glenoid labrum is excised circumferentially to expose the entire surface of the glenoid. Any remaining portions of the biceps tendon also should be excised. There is often a significant amount of tissue around the glenoid that represents bursal tissue and remnants of rotator cuff tendons. This should be excised to enhance visualization. The superior, anterior and inferior capsule should be released both for exposure and mobilization. A posterior capsular release may be beneficial to allow the proximal humerus to be retracted posteriorly for adequate glenoid exposure.

At this point, the degree and location of glenoid erosion can be visualized. This should be carefully and completely assessed so that glenoid reaming can be performed to provide proper orientation of the glenoid component. Exposure of the glenoid also will be facilitated by use of specific retractors. For a deltopectoral approach, a Posterior Glenoid Retractor is essential. The **Forked Retractor** provided in the instrument set can be useful for this purpose. The large Darrach Retractor provided can also be used. Levering retractors should be placed anteriorly, superiorly and inferiorly to expose the glenoid margins.

When a superior approach is used, the inferior capsular release is particularly important. The Forked Retractor can then be placed inferiorly to retract the proximal humerus posteroinferiorly for glenoid exposure. Levering retractors should be placed anteriorly, superiorly and posteriorly as described.

Note: While the Equinox® Glenoid Plate does not need to be inferiorly tilted or angled, it should not be implanted with a superior tilt. A neutral orientation is ideal.

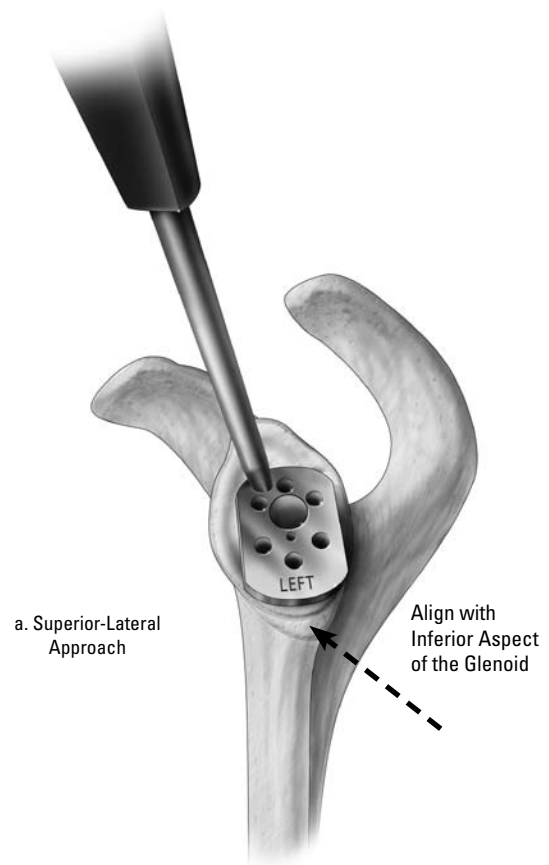
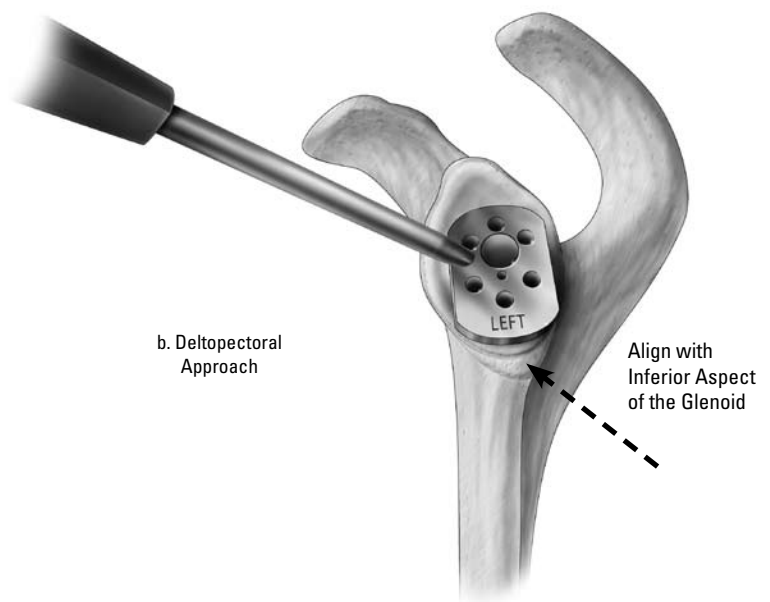

Figure 9a and 9b
Aligning Drill Guide with Inferior Aspect of the Glenoid



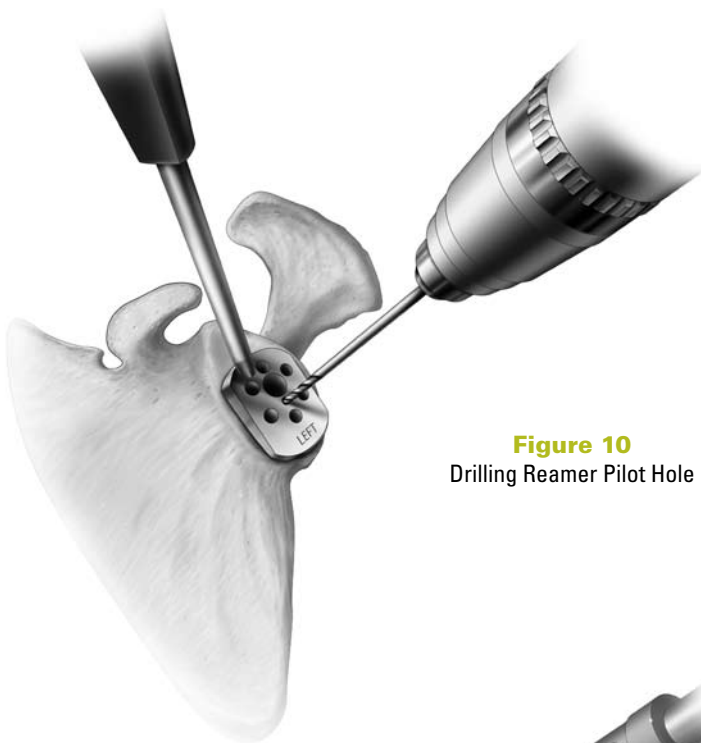

Figure 10
Drilling Reamer Pilot Hole

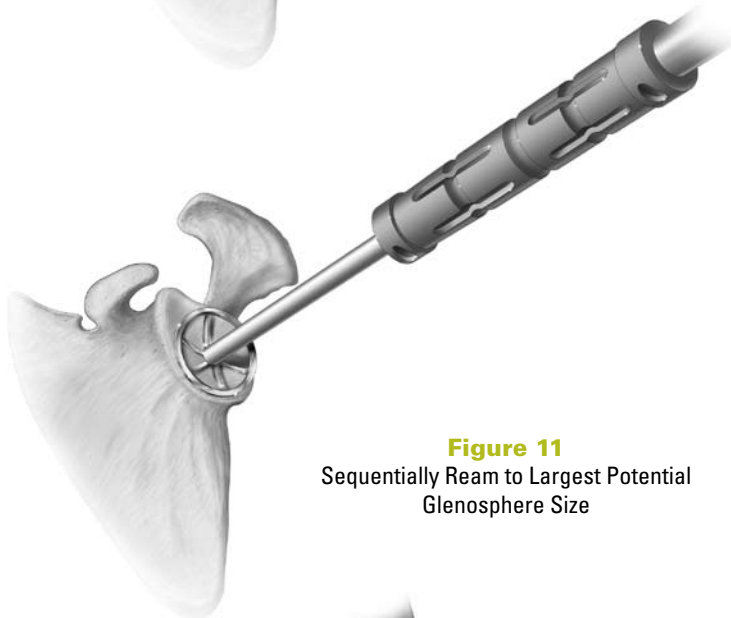

Figure 11
Sequentially Ream to Largest Potential
Glenosphere Size

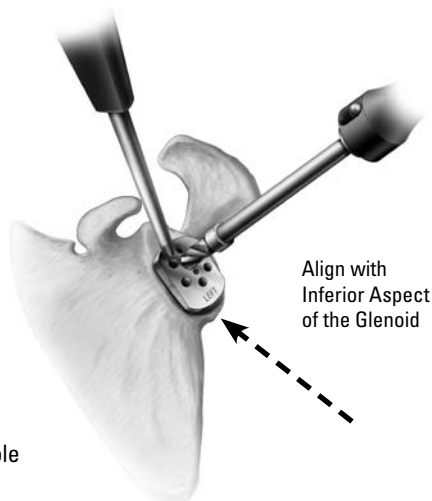

Figure 12
Drilling Glenoid Plate Hole

Drilling Pilot Hole for Glenoid Reamer

The **inferior aspect** of the **Glenoid Plate Drill Guide** is aligned with the **inferior aspect** of the native glenoid bone after removing any inferior glenoid osteophyte (*Figure 9*). This ensures the glenosphere is properly positioned in a superior-inferior position. Palpate the anterior glenoid neck to determine the angle for glenoid reaming. The 2mm pilot hole is drilled to create the central axis for reaming the glenoid (*Figure 10*).

Note: Two handle orientations are offered for the two different surgical approaches.

Reaming the Glenoid

The reamer tip is placed into the drilled pilot hole and the glenoid is sequentially reamed until any pre-identified glenoid erosions are corrected and the glenoid surface has been fully contoured (*Figure 11*). Reaming begins with the **Reverse Shoulder Starter Reamer** and progresses to the 38mm and 42mm sizes based upon the anticipated size of the glenosphere. **It is critical to ream to the size of the largest potential glenosphere that the surgeon might use to ensure that the glenosphere will fit on the face of the glenoid without peripheral bony impingement (i.e. the glenoid plate will already be fixed to the glenoid and upsizing the glenosphere during trialing will not be possible if the corresponding reaming has not already been performed).** Reamers are available in color-coded sizes that correspond to the two sizes of Glenospheres as described in the table below.

Table 1 Color-coded Reamers and Trials

Size	Color of Reamer and Trials
38	Blue
42	Yellow
46*	Orange

* special order

Drill Cage Hole through Drill Guide

After reaming has been completed, the **inferior aspect** of the Glenoid Plate Drill Guide is aligned with the **inferior aspect** of the glenoid (i.e. same position used for drilling the pilot hole). The cage hole is drilled to prepare the glenoid for the Glenoid Plate (*Figure 12*). The **Glenoid Plate Drill** is 7.3mm in diameter. The glenoid plate cage is tapered and varies in diameter between 7.5mm at its end to 8.1mm where it joins the back of the Glenoid Plate.

Bone Graft for Glenoid Plate

Two options exist for placing bone graft in the glenoid plate's cage (*Figure 13*).

1. Using the **Glenoid Plate Coring Reamer** to create a 6mm autograft bone column from the humeral head, or other suitable location as deemed appropriate by the surgeon, and inserting the bone column directly into the cage.

2. Placing allograft (e.g. 1cc of either Optecure® with CCC or Optecure in a syringe) or morsalized autograft manually into the cage.

Note: Take care to prevent bone graft from getting on the screw-hole threads as this could prevent adequate screw engagement.

Implanting the Glenoid Plate

Once the cage hole is drilled, the Glenoid Plate is attached to the **Glenoid Plate Inserter** and the Glenoid Plate is press fit into position taking care to respect the correct rotational orientation (*i.e. the plate should align with the superior/inferior axis of the glenoid*) (*Figure 14*). The Inserter connects to the **bottom half** of the Glenoid Plate such that the central pin aligns with the threaded central hole and the peripheral legs connect to the bottom peripheral holes of the Glenoid Plate.

Four of the six potential screw locations that will provide optimal fixation and support of the glenoid plate are identified. Primary reverse shoulders will most typically use the superior and three inferior holes based on the anatomy of the native glenoid. The two peripheral holes on the superior part of the plate are intended for revision cases in which the native glenoid bone is compromised. However, each case should be individualized and the six holes provide the surgeon with additional options to maximize fixation of the Glenoid Plate (*Figure 15*).

Four holes should be drilled using the **Adjustable Angle Drill Guide** and the **3.2mm Drill** (*Figure 16*), taking note of the depth of each hole using either the color-coded drill or the traditional depth guide. Each hole allows 30 degrees of angular variability so the orientation of the screws can be selected to maximize purchase. (Note: The central cage of the glenoid plate limits the angular variability to 20 degrees for converging anterior, posterior and superior screws.) The inferior screw should track along the inferior scapular neck and the superior screw should be targeted to track along the base of the coracoid (*Figure 17*). The anterior and posterior screws should be inserted where the surgeon feels the best bone purchase can be achieved, taking note not to drill into the central cage of the Glenoid Plate.

The 4.5mm **Compression Screws** are provided in lengths between 18mm and 46mm, in 4mm increments. The appropriately sized Compression



Figure 13
Assembling the Glenoid Plate with Bone Graft



Figure 14
Inserting Glenoid Plate



Figure 15
Implanted Glenoid Plate

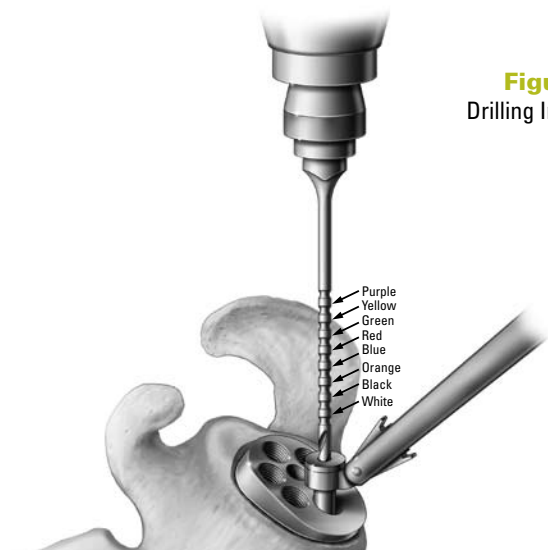

Figure 16
Drilling Inferior Hole

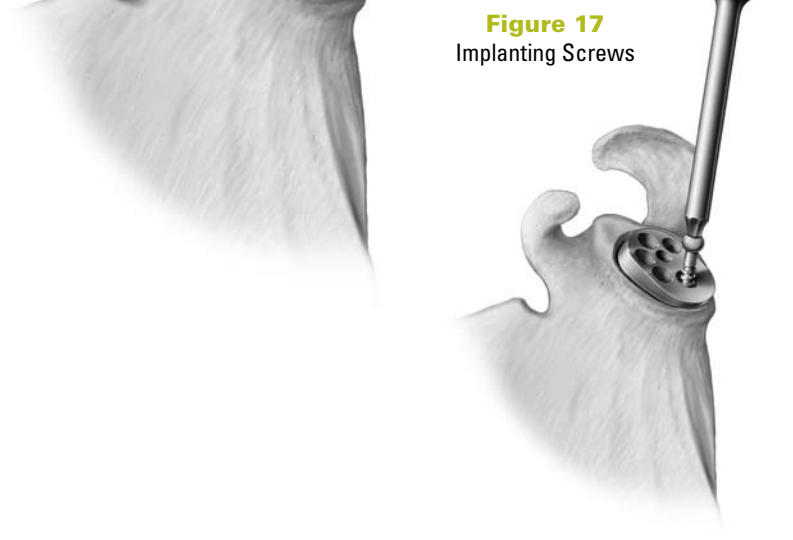

Figure 17
Implanting Screws

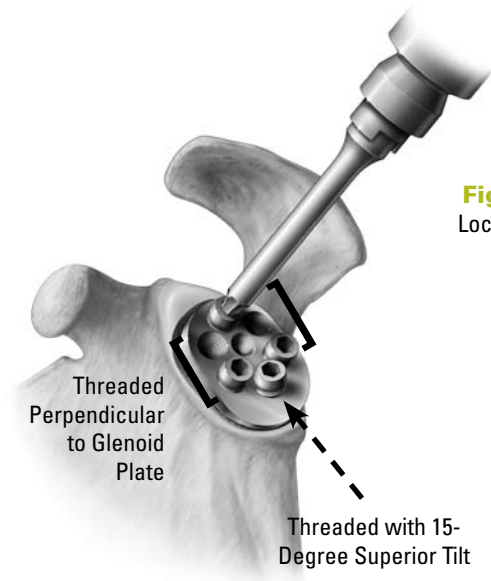

Figure 18
Locking Caps

Screws (Table 2) are inserted into the drilled holes to achieve fixation and compression of the Glenoid Plate to the glenoid. If power is used to initially insert the screws, caution should be taken to perform the final seating by hand. This will maximize fixation. A **Ratcheting Screw Drive** is included in the instrument set to facilitate the placement and tightening of the screws.

Table 2 Compression Screws

Length (mm)	Diameter (mm)	Color-code
18	4.5	White
22	4.5	Black
26	4.5	Orange
30	4.5	Blue
34	4.5	Red
38	4.5	Green
42	4.5	Yellow
46	4.5	Purple

After all Compression Screws are tightened by hand, as deemed appropriate by the orthopaedic surgeon, the surgeon should insert the **Locking Caps** into each screw hole. This will lock each Compression Screw and prevent the screws from backing out. **Each Locking Cap is inserted perpendicular to the plate with the exception of the inferior one, which must be threaded at a 15-degree superior tilt (Figure 18).**

Inserting the Glenosphere Trial

Attaining adequate glenoid exposure is critical for this step, especially posterior glenoid exposure. The Posterior Glenoid Retractor included in the set can help provide the posterior clearance necessary to implant the **Glenosphere**.

The appropriately sized Glenosphere is defined by implanting the largest one that can be inserted based upon exposure and the coracoacromial arch anatomy (ensuring that it was reamed up to that size during the glenoid reaming step). **Take note that unlike circular baseplates, the anatomical shape of the Equinox Glenoid Plate mandates that the Glenosphere can only fit in one specific orientation (i.e. the superior/inferior axis of the glenoid).**

The Pilot Glenosphere Inserter: While several options are available for Glenosphere insertion, the preferred method is the **Pilot Glenosphere Inserter**. Attach the **T-Handle** to the inserter and lightly impact it into the glenosphere to provide rotational stability. Align the T-Handle in the north/south axis of the glenosphere to ensure that it is properly oriented with the Glenoid Plate. The pilot tip fits into the baseplate to aid in orienting the glenosphere onto the baseplate. Once the glenosphere is seated on the baseplate, apply digital pressure to ensure the glenosphere stays on the baseplate and remove the inserter. Do not attempt to impact the Pilot Glenosphere Inserter once the glenosphere is seated (*Figure 19a*).

The Tapered Glenosphere Inserter: Attach the **Tapered Glenosphere Inserter** in the same manner as the Pilot Glenosphere Inserter. This instrument provides rotational stability and axial control. Since the instrument is cannulated, a 0.062 inch guide wire or K-wire can be inserted into the bone cage of the Glenoid Plate to aid with insertion (*Figure 19b*).

Finally, the GlenosphereTrial is connected to the Glenoid Plate with the **Glenosphere Locking Screw** to prevent the Glenosphere from disengaging during trial reductions.

Step 5: Trialing the Humeral Adapter Tray and Liner

The +0mm **Humeral Adapter Tray Trial** is attached to the humeral stem by threading the **Humeral Adapter Tray Captured Screw** into the Humeral Stem's screw hole (*Figure 21*) (+10mm is also attached this way). **It is critical that the Humeral Adapter Tray be oriented such that the line on the Adapter Tray aligns with the lateral fin of the Humeral Stem.** The +5mm trial tray can be added as needed. For a +10mm offset and greater, remove the +0mm Humeral Adapter Tray Trial and insert the +10mm tray trial. To obtain a +15mm offset (special order) and larger, the +5mm tray trial will need to be added. Combinations of trays and liners can achieve the following offsets: +0, +2.5, +5.0, +7.5, +10.0, +12.5mm and available by special order +15 and +17.5mm. It is important to note that the assembled humeral component will have a humeral neck angle of 145 degrees because the liner adds 12.5 degrees to the stem's 132.5 degree neck angle (*Figure 22*).

Note: When threading the **Glenosphere Locking Screw**, take note that the hole is not at the apex of the Glenosphere, which can make the screw appear to be going in off-axis. The screw is threaded to the baseplate in an orientation that is perpendicular to the baseplate, but this is not perpendicular to the hole in the Glenosphere (*Figure 20*).

Figure 19
Inserting Glenosphere Trial

19a
Pilot Tapered Glenosphere Inserter

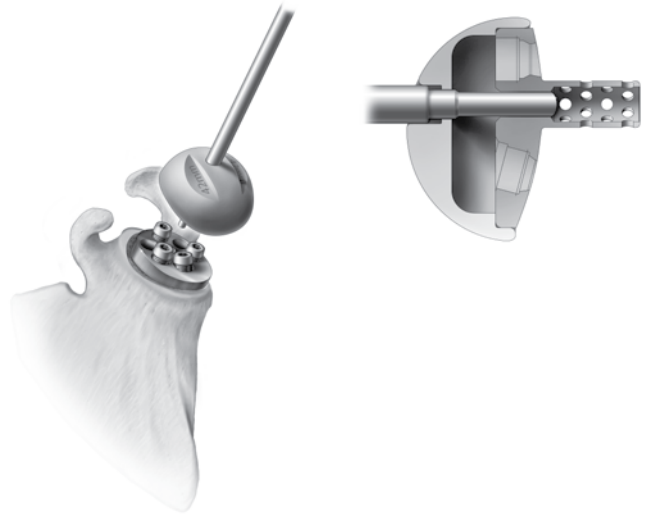

19b
Tapered Glenosphere Inserter

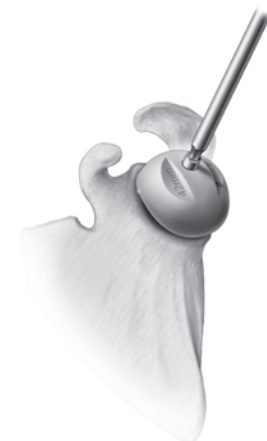
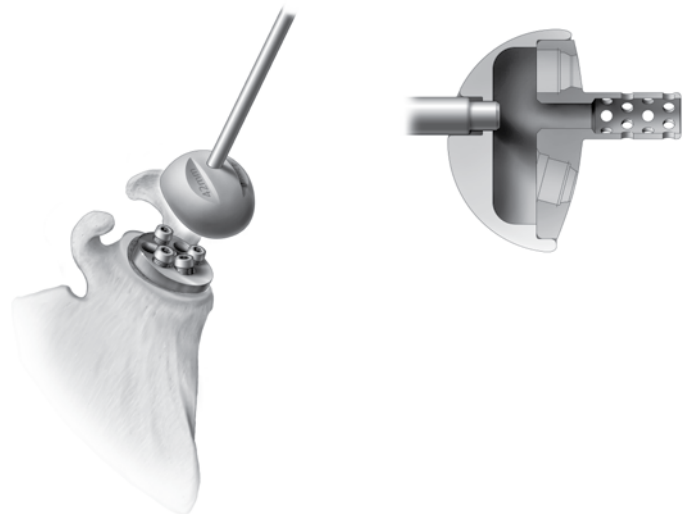

Figure 20
Glenosphere
Locking Screw



Figure 21
Humeral Tray Trial



Figure 22
Humeral Tray Trial
and Liner Trial



Figure 23
Liner Trial Removal

To insert the **Humeral Liner Trial** into the Trial Tray, the underside asymmetric-connecting feature should be appropriately aligned and the liner/tray trials should be pressed together until the C-spring engages. To disengage the trials, the tip of the **Humeral Liner Removal Tool** is inserted into the recessed region of the trial tray and the instrument is turned like a key until the spring that connects the Humeral Liner Trials and plate trials is disengaged, thereby freeing the Liner (*Figure 23*).

The stability of the implant is assessed during a trial reduction. The shoulder should be placed through a range of motion to assess the stability of the construct. While each surgeon may have their own system to assess stability, we approach the trial reduction as follows:

1. With reduction and arm by the side, the lateral deltoid and conjoined tendon should be under tension. The expectation is that the reduction should require more distraction to achieve than reduction of non-constrained implants.
2. Forward elevation and abduction should be assessed to determine that the construct is stable and the components do not impinge on bony structures.
3. Internal and external rotation should be assessed with the humerus at 0 and 90 degrees to assess stability. Although maximal ranges of external rotation may produce some impingement posteriorly, it should not result in instability.
4. With the arm at the side, there should be no evidence of impingement that results in distraction of the implants.

If additional stability is required based upon the trial reduction, constrained liner options are provided in the same offset as the standard liners. While constrained liners will provide better stability, it is important to note they will also reduce the potential range of motion that can be achieved. If tension is inadequate, additional offset can be added up to 12.5mm. If trial components are changed, additional closed reductions and assessments should be performed to confirm that the desired stability has been obtained. In the unusual situation in which the +0mm liner is too tight, the humeral component should be removed and additional bone should be resected using the methods described.

INSERTING THE FINAL IMPLANTS

The Humeral Liner Trial, Humeral Adapter Tray Trial and Glenosphere Trial are removed. The final Glenosphere is implanted in the same manner used with the Glenosphere Trial. Impaction of the glenosphere is not necessary since it is not a Morse taper. The Glenosphere is secured with the Glenosphere Locking Screw, which employs a Spirallock® technology (*Figure 24*).

The arm should be placed in extension and the Primary Stem Inserter should be attached to the humeral stem. The stem can now be removed in order to prepare for cementing the stem. **Downsizing the definitive stem from the trial will result in a 1.5mm proximal cement mantle and a 2mm distal cement mantle. Alternatively, the proximal humerus can be broached one size larger than the trial stem (the broaches are tapered distally to allow this technique) and the same size stem can be used as the trial. This provides for a 1.5mm proximal cement mantle and a line-to-line fit distally.** In the majority of cases, the proximal humerus will tolerate broaching an additional size to accommodate the cement mantle (i.e. if an 11mm stem was used, then a 13mm Broach should be inserted to prepare for cementing). However, the Broach must not be forced if there is not adequate proximal humerus to fully seat the larger broach. Adequate stability can still be obtained with a minimal cementation technique. Cementing of the stem should proceed based upon the surgeon's preferred technique (*Figure 25*). The Stem Inserter should be used with the stem impacted into place until it is at the level of the bony surface.

The final Humeral Adapter Tray is attached to the Humeral Stem using the **Reverse Torque Defining Screw** (*Figure 26*). **It is critical that the Humeral Adapter Tray be oriented properly, which requires aligning the indicator mark on the tray with the lateral fin on the stem.** The plate is locked to the stem by applying 11 N*m torque to the Screw with the supplied driver while countering the torque to the arm with the **Reverse Shoulder Modular Replicator Handle**. The superior portion of the Screw will disengage when 11 N*m is reached (and will remain in the Screw Drive, both of which are disposable).

The final Humeral Liner is attached to the Humeral Adapter Tray by orienting the asymmetric connecting features **and sliding the lip of the liner under the superior rim of the Humeral Tray**. As with the trial insertion, it is important to note that the assembled humeral component will have a humeral neck angle of 145 degrees because the Humeral Liner adds 12.5 degrees to the stem's 132.5-degree neck angle. Finally, the apical mushroom of the Humeral Liner is engaged to the apical lock of the Humeral Adapter Tray by impacting the Humeral Liner with the appropriately sized **Humeral Liner**

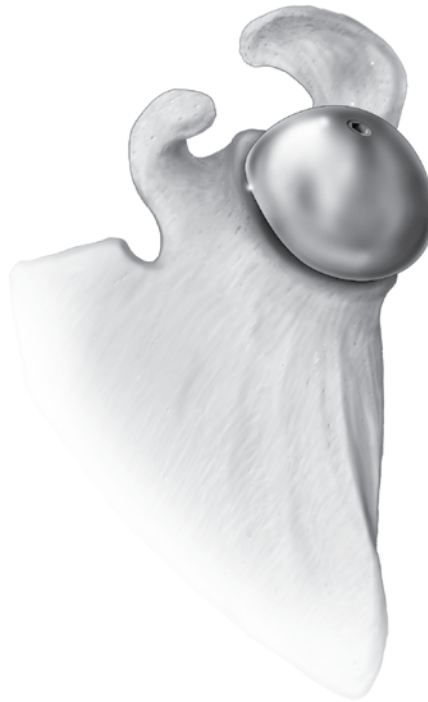

Figure 24
Inserting Definitive
Glenoid and Screw



Figure 25
Cementing Definitive Stem

Figure 26
Locking Torque Defining Screw

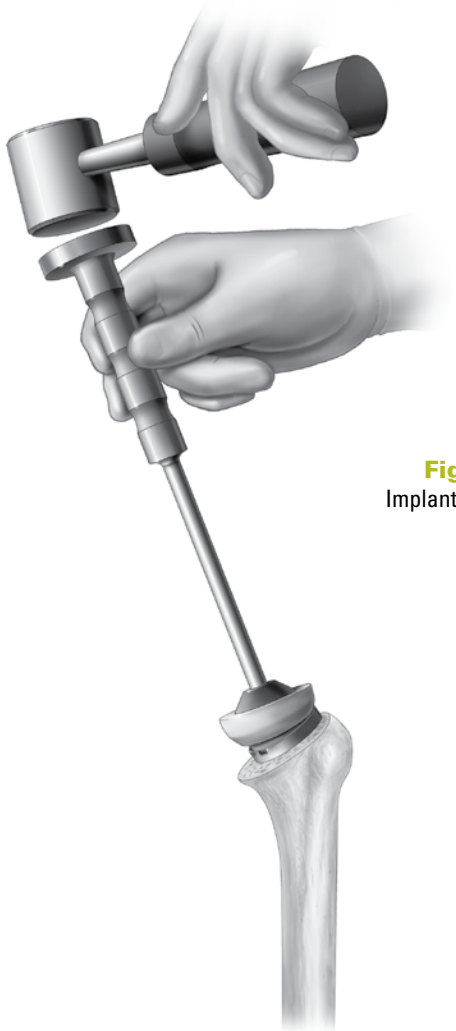

Figure 27
Implanting Definitive
Liner

Impactor Tip (Table 3). The humeral liner should be impacted until it sits flush on the Humeral Adapter Tray (Figure 27).

Table 3 Impactor Tips

Size	Color of Impactor Tips
38	Blue
42	Yellow
46*	Orange

* special order

At this point, the humeral component should be reduced onto the Glenosphere. Range of motion and stability should be assessed to confirm the findings from the trial reduction. Once this assessment has been made, closure can be performed.

Alternatively, the stem, tray and liner can be assembled on the back table first and then placed as a unit into the humerus with cement. The disadvantage of this technique is that further implant trialing is not possible so it should only be used when the surgeon is confident about the thickness of the tray and liners based on the previous trialing. The advantage of this technique is that the shoulder can be reduced and the surgeon can begin closing while the cement is hardening.

Step 6a: Deltpectoral Closure

If the subscapularis tendon was divided during the approach it should be reattached at this time. The method of reattachment is based upon surgeon preference and is generally determined by the method of tenotomy performed. The repair will be either tendon-to-tendon or tendon-to-bone using #2 heavy non-absorbable sutures. We prefer the use of a drain because of the relatively large dead-space and the potential for hematoma formation. The use of a drain will limit the risk of hematoma formation. The deltopectoral interval is closed followed by closure of the subcutaneous tissue and the skin. The upper extremity is then placed in a sling and swathe.

Step 6b: Superior-Lateral Closure

A drain should be inserted to minimize the risk of post-operative hematoma formation. The anterior deltoid should be repaired directly to the anterior acromion with #2 non-absorbable sutures passed through drill holes. The split between the anterior and middle deltoid should be repaired with absorbable sutures. The subcutaneous tissue layer is then closed, followed by the skin closure. The upper extremity is then placed in a sling and swathe.

Radiographs are usually obtained in the operating room to document the position and alignment of the implants. The specific views obtained are based upon surgeon preference.

Glenosphere Removal

If the Glenosphere needs to be removed, the removal instrument can be used to hook into the anterior and posterior recesses on the underside of the Glenosphere to lever it off of the baseplate (Figure 28).

Step 7: Post-Operative Rehabilitation

The rehabilitation program can be carefully started on the same day as surgery or by post-operative day one. All patients should begin active range of motion of the elbow, wrist and hand. Range of motion of the shoulder consists of passive forward elevation, external rotation based on the intra-operative assessment and internal rotation to the chest wall. Isometric deltoid strengthening can also be started on post-operative day one. Patients should be instructed to perform these exercises five to six times per day for short periods of up to 10 minutes each session.

Some surgeons may prefer to treat the patient in a sling with no shoulder rehabilitation for a period of three to four weeks. **It is very important that caregivers do not pull up on the operated arm of the patient in an effort to assist the patient from bed or a chair as this might cause dislocation.**

The sling is discontinued after six weeks. A longer period of sling use is indicated if there is concern about the stability of the joint. When the sling is discontinued, active and active-assisted range of motion should begin. Internal rotation behind the back can also be started at this time. Isometric internal and external rotation is added at six weeks and gentle resistive strengthening of the deltoid and rotator cuff begins 10-12 weeks post-operatively. When the sling is removed, the patient is instructed to increase use of the upper extremity for activities of daily living.

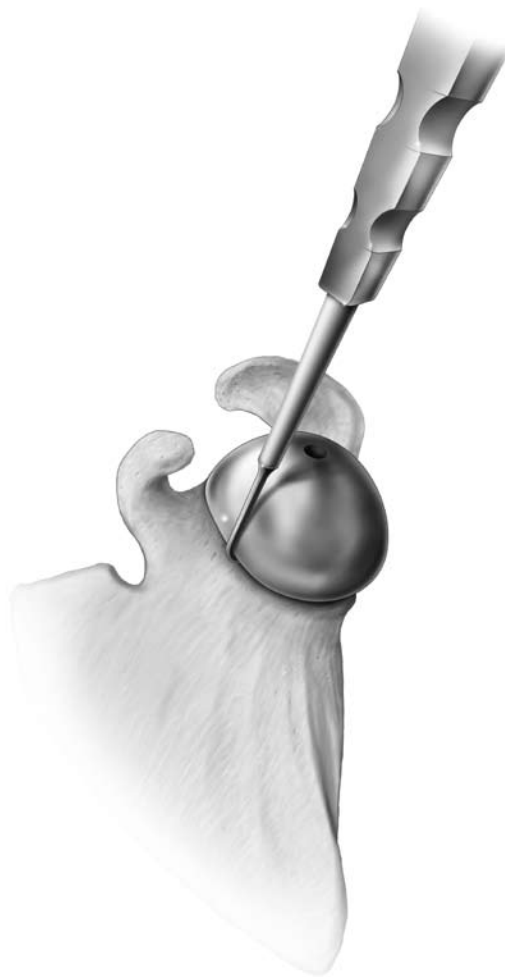
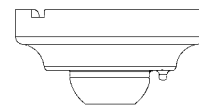

Figure 28
Removing Glenosphere

EQUINOXE IMPLANT SCOPE

Humeral Adapter Trays

320-10-00	Equinox, Reverse Shoulder, Humeral Adapter Tray, +0
320-10-05	Equinox, Reverse Shoulder, Humeral Adapter Tray, +5
320-10-10	Equinox, Reverse Shoulder, Humeral Adapter Tray, +10
320-10-15*	Equinox, Reverse Shoulder, Humeral Adapter Tray, +15



Reverse Torque Defining Screw Kit

320-20-00	Equinox, Reverse Shoulder, Torque Defining Screw Kit
-----------	--

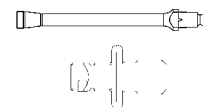

Reverse Humeral Liners

320-38-00	Equinox, Reverse Shoulder, Humeral Liner, 38mm, +0
320-38-03	Equinox, Reverse Shoulder, Humeral Liner, 38mm, +2.5
320-38-10	Equinox, Reverse Shoulder, Constrained Humeral Liner, 38mm, +0
320-38-13	Equinox, Reverse Shoulder, Constrained Humeral Liner, 38mm, +2.5
320-42-00	Equinox, Reverse Shoulder, Humeral Liner, 42mm, +0
320-42-03	Equinox, Reverse Shoulder, Humeral Liner, 42mm, +2.5
320-42-10	Equinox, Reverse Shoulder, Constrained Humeral Liner, 42mm, +0
320-42-13	Equinox, Reverse Shoulder, Constrained Humeral Liner, 42mm, +2.5
320-46-00*	Equinox, Reverse Shoulder, Humeral Liner, 46mm, +0
320-46-03*	Equinox, Reverse Shoulder, Humeral Liner, 46mm, +2.5
320-46-10*	Equinox, Reverse Shoulder, Constrained Humeral Liner, 46mm, +0
320-46-13*	Equinox, Reverse Shoulder, Constrained Humeral Liner, 46mm, +2.5

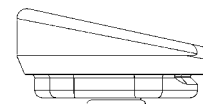

Glenospheres

320-01-38	Equinox, Reverse Shoulder, Glenosphere, 38mm
320-01-42	Equinox, Reverse Shoulder, Glenosphere, 42mm
320-01-46*	Equinox, Reverse Shoulder, Glenosphere, 46mm

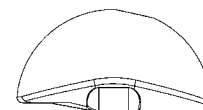

Compression Screw/Locking Cap Kits

320-20-18	Equinox, Reverse Shoulder, Compression Screw/Locking Cap Kit, 4.5 x 18mm	White
320-20-22	Equinox, Reverse Shoulder, Compression Screw/Locking Cap Kit, 4.5 x 22mm	Black
320-20-26	Equinox, Reverse Shoulder, Compression Screw/Locking Cap Kit, 4.5 x 26mm	Orange
320-20-30	Equinox, Reverse Shoulder, Compression Screw/Locking Cap Kit, 4.5 x 30mm	Blue
320-20-34	Equinox, Reverse Shoulder, Compression Screw/Locking Cap Kit, 4.5 x 34mm	Red
320-20-38	Equinox, Reverse Shoulder, Compression Screw/Locking Cap Kit, 4.5 x 38mm	Green
320-20-42	Equinox, Reverse Shoulder, Compression Screw/Locking Cap Kit, 4.5 x 42mm	Yellow
320-20-46	Equinox, Reverse Shoulder, Compression Screw/Locking Cap Kit, 4.5 x 46mm	Purple



Glenosphere Locking Screw

320-15-05	Equinox, Reverse Shoulder, Glenosphere Locking Screw
-----------	--



Glenoid Plate

320-15-01	Equinox, Reverse Shoulder, Glenoid Plate
-----------	--

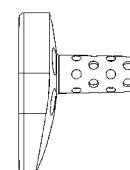

* special order

EQUINOXE IMPLANT SCOPE

Primary Humeral Stems

300-01-07	Equinox, Humeral Stem, Primary, 7mm
300-01-09	Equinox, Humeral Stem, Primary, 9mm
300-01-11	Equinox, Humeral Stem, Primary, 11mm
300-01-13	Equinox, Humeral Stem, Primary, 13mm
300-01-15	Equinox, Humeral Stem, Primary, 15mm
300-01-17	Equinox, Humeral Stem, Primary, 17mm

Revision Humeral Stems

306-01-08	Equinox, Humeral Stem, Revision, 8 x 175mm
306-02-08	Equinox, Humeral Stem, Revision, 8 x 215mm
306-02-10*	Equinox, Humeral Stem, Revision, 10 x 200mm
306-02-12*	Equinox, Humeral Stem, Revision, 12 x 200mm

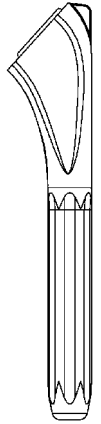

* special order

EQUINOXE REVERSE INSTRUMENT SCOPE

321-10-00	Humeral Adapter Tray Trial Assembly (+0)	321-07-38	Humeral Liner Impactor Tip (38mm)
321-10-01	Humeral Adapter Tray Captured Screw	321-07-42	Humeral Liner Impactor Tip (42mm)
321-10-05	Humeral Adapter Tray Trial Assembly (+5)	321-07-46*	Humeral Liner Impactor Tip (46mm)
321-10-10	Humeral Adapter Tray Trial Assembly (+10)	321-15-00	Glenoid Plate Drill Guide - Left, Superior Lateral
321-10-11	Humeral Adapter Tray Trial Assembly, Captured Screw (+10)	321-15-01	Glenoid Plate Drill Guide - Right, Superior Lateral
321-38-00	38mm Humeral Liner Trial (+0)	321-15-02	Glenoid Plate Drill Guide - Left, Deltopectoral
321-38-03	38mm Humeral Liner Trial (+2.5)	321-15-03	Glenoid Plate Drill Guide - Right, Deltopectoral
321-38-10	38mm Humeral Liner Trial Constrained (+0)	321-15-04	Adjustable Angle Drill Guide
321-38-13	38mm Humeral Liner Trial Constrained (+2.5)	321-15-06	2.0mm Drill**
321-42-00	42mm Humeral Liner Trial (+0)	321-15-07	3.2mm Drill**
321-42-03	42mm Humeral Liner Trial (+2.5)	321-15-08	Hex Screwdriver (3.5mm)
321-42-10	42mm Humeral Liner Trial Constrained (+0)	321-15-09	Glenoid Screw Depth Gauge
321-42-13	42mm Humeral Liner Trial Constrained (+2.5)	315-07-60	Glenoid Plate Drill
321-46-00*	46mm Humeral Liner Trails (+0)	321-15-11	Humeral Liner Removal Tool
321-46-03*	46mm Humeral Liner Trails (+2.5)	321-15-13	Glenoid Plate Inserter/Impactor
321-46-10*	46mm Constrained Humeral Liner Trails (+0)	321-07-10	Glenoid Plate Coring Reamer
321-46-13*	46mm Constrained Humeral Liner Trails (+2.5)	321-10-35	Reverse Shoulder Modular Replicator Handle
321-01-05	Glenosphere Impactor	301-07-80	Screw Drive Handle (Ratcheting)
321-01-30	Extended Flexible Glenosphere Inserter Slide	317-20-01	Forked (Playboy) Retractor – Small
321-02-15	Glenosphere Removal Hook	317-20-02	Forked (Playboy) Retractor – Large
321-03-10	Cannulated Glenosphere Inserter Screw	317-20-03	Deltoid Retractor
321-01-38	38mm Glenosphere Trial	321-01-00	Glenosphere Inserter Square
321-01-42	42mm Glenosphere Trial	321-01-01	Modular Glenosphere Inserter Square
321-01-46*	46mm Glenosphere Trial	321-01-25	Tapered Glenosphere Inserter
321-02-38	38mm Glenosphere Inserter Clamp - Left	321-01-26	Pilot Glenosphere Inserter
321-03-38	38mm Glenosphere Inserter Clamp - Right	321-01-07	7mm Humeral Stem Trial
321-02-42	42mm Glenosphere Inserter Clamp - Left	321-01-09	9mm Humeral Stem Trial
321-02-46*	46mm Glenosphere Inserter Clamp - Left	321-01-11	11mm Humeral Stem Trial
321-03-42	42mm Glenosphere Inserter Clamp - Right	321-01-13	13mm Humeral Stem Trial
321-03-46*	46mm Glenosphere Inserter Clamp - Right	321-01-15	15mm Humeral Stem Trial
321-05-01	Reverse Shoulder Starter Reamer	321-01-17	17mm Humeral Stem Trial
321-05-38	38mm Glenoid Reamer	321-02-08	8mm x 175mm Humeral Long Stem Trails
321-05-42	42mm Glenoid Reamer	321-02-10	10mm x 200mm Humeral Long Stem Trails*
321-05-46*	46mm Glenoid Reamer	321-02-12	12mm x 200mm Humeral Long Stem Trails*
321-07-05	Impactor Handle	321-03-08	8mm x 215mm Humeral Long Stem Trails
			Existing Equinoxe Primary Instruments for Humerus

* special order

** packaged sterile in kit 321-20-00

REFERENCES

1. **Roche C, Flurin PH, Wright T, Crosby L, Zuckerman J.** Proceedings of the 2006 ISTA Meeting. New York, NY. 2006.

2. **Roche C, Flurin PH, Wright T, Crosby L, Zuckerman J.** Proceedings of the 53rd Annual ORS Meeting. San Diego, CA. 2007.

3. Data on file at Exactech

For additional device information, refer to the Exactech Equinox Shoulder System – Instructions for Use.

For further product information, please contact Customer Service, Exactech, Inc., 2320 NW 66th Court, Gainesville, Florida 32653-1630, USA. (352) 377-1140, (800) 392-2832 or FAX (352) 378-2617.

Authorized European Representative
MediMark® Europe
11, rue Emile Zola B.P. 2332
38033 Grenoble Cedex 2
France

Worldwide Offices

Exactech Corporate Headquarters

2320 NW 66th Court
Gainesville, FL 32653 USA
Tel: +1 800-EXACTECH
+1 352-377-1140
Fax: +1 352-378-2617
+1 800-329-3922

Exactech Asia

Room 825 CIMIC Tower
1090 Century Boulevard
Pu Dong, Shanghai 200120
P.R. China
Tel: +86 21-5835-3677
Fax: +86 21-5054-1683

Exactech Canada

2-3055 Homestead Drive
Mount Hope, ON
LOR 1W0
Canada
Tel: +1 866-549-7600
+1 905-679-1100
Fax: +1 905-679-1200

Exactech Japan

1-23-1, Ooi, Shinagawa-ku
Tokyo 140-0014
Japan
Tel: +81 3-37-781200
Fax: +81 3-37-781300

Exactech United Kingdom

Grosvenor House
Prospect Hill, Redditch
B97 4DL United Kingdom
Tel: +44 1527-591-555
Fax: +44 1527-591-044

France Medica A subsidiary of Exactech

Parc D'Innovation
Le Pythagore BP 40154
Rue Jean Sapidus
67404 Illkirch Cedex, France
Tel: +33 388-673-712
Fax: +33 388-664-420

352-377-1140
1-800-EXACTECH
www.exac.com

