

SHOULDER

Operative Technique



GPS Shoulder 3.1 and 3.1.1
Using Equinoxe® Legacy,
Ergo and Cannulated
Instruments



TABLE OF CONTENTS

GPS SHOULDER APPLICATION WORKFLOW OVERVIEW.....	2
DETAILED STEPS PRIOR TO GPS.....	3
Patient and Station Positioning.....	3
Surgical Step - Glenoid Preparation.....	4
Surgical Step - Coracoid Block Placement.....	11
Case and Instrument Selection.....	13
Connecting Trackers.....	14
Final Confirmation.....	15
Probe Orientation.....	16
Surgical Acquisitions.....	17
Verify Acquisitions.....	20
DETAILED OPERATIVE TECHNIQUE.....	22
Legacy Anatomic Shoulder.....	22
Legacy Reverse Shoulder.....	32
ERGO Anatomic Shoulder.....	45
ERGO Reverse Shoulder.....	57
Cannulated Anatomic Shoulder.....	72
Cannulated Reverse Shoulder.....	78

The GPS Shoulder Application was developed in conjunction with:



Ian Byram, MD

Bone and Joint Institute
of Tennessee
Nashville, TN

Emilie V. Cheung, MD

Stanford University
Palo Alto, CA

Pierre Henri Flurin, MD

Bordeaux-Merignac Clinic
Bordeaux, France

Bruno B. Gobbato

Jaraguá do Sul
Santa Catarina, Brazil

Richard B. Jones, MD

Southeastern Sports Medicine
Asheville, NC

Gabriella E. Ode, MD

HSS Sport Medicine Institute
Brooklyn, NY

Rick Papandrea, MD

Orthopaedic Associates
of Wisconsin
Milwaukee, WI

Moby Parsons, MD

The Knee Hip and Shoulder Center
Portsmouth, NH

Paul Saadi, MD

Dallas Bone and Joint
Dallas, TX

Thomas Wright, MD

University of Florida
Gainesville, FL

Ari Youderian, MD

SCOS Orthopedic Specialists
Orange County, CA

Joseph Zuckerman, MD

NYU Langone
Orthopedic Hospital
New York, NY



Screen Layout

Icon		Description
	Switch OFF	Switch OFF the station.
	AUGI App	Connect to AUGI App.
	Tools	Access maintenance options.
	Change Language	Change the default language of the software.
	Total Shoulder	Access detailed options related to total shoulder application.
	Screenshot	Take a screen shot of the current screen. The picture is recorded in the operative report.
	Go Forward	Go to the next step.
	Go Backward	Go to the previous step.
	Menu	Access to options (exit, reconnect trackers...)
	Exit	Exit the shoulder application.

GPS SHOULDER APPLICATION WORKFLOW OVERVIEW

Workflow: Preoperative Planning and GPS Surgery

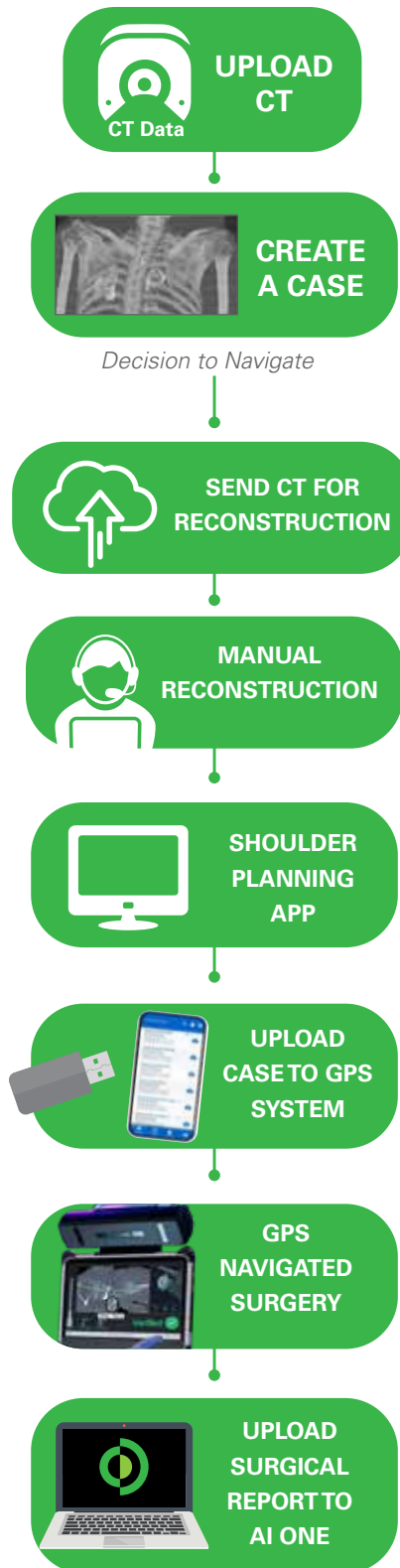

DETAILED STEPS PRIOR TO GPS

PATIENT AND STATION POSITIONING

Patient Positioning

The patient should be placed on an operating table in a supine position. The head of the operating table should be elevated approximately 30° in a modified beach chair position. A small bolster should be placed laterally behind the involved shoulder. The patient should be moved to the side of the table so that the upper extremity can be placed into maximum extension without obstruction by the operating table. Alternatively, a Captain's chair or similar positioning device can be used for proper patient positioning. The patient should be secured to the operating table to minimize any changes in position intraoperatively.

Once the patient is secure, the extremity is examined to assess the range of motion, with particular attention to external rotation with the arm at the side. If external rotation is restricted (i.e. internal rotation contracture) the need for more extensive subscapularis mobilization or lengthening procedures may be necessary. The entire upper extremity should be prepped to allow complete access to the operative area and full mobility during the procedure.

Station Positioning

With the patient in place, the GPS station may be set up. The station should be placed near the patient's opposite hip where visibility is optimal. Attach the GPS clamp to the bed rail under the patient's hips on the contralateral side, assuming there is one rail under the back, one rail under the hips, and one rail under the lower legs. Bring the clamp all the way up to the edge of the bed rail under the hips, toward the patient's head.

If patient positioning is too flat or supine, Tracker visibility with the station could be impeded. If the surgeon prefers not to adjust the patient position to a beach chair angle, the station should be adjusted on the table closer and superior to the hip. The arm holder/pad for the non-operative arm should be positioned toward the head (elbow pulled back) so the station can sit higher on the rail for better line of sight to the tracker.

Drape the patient once the station is in the optimal position (GPS station and arm are attached to bed rail). Connect all cables and the USB key before draping. Once the GPS station is draped, connectors are not accessible. Take the sterile drape by the two tabs and place it on the GPS Station from the top, with the transparent sheet on the screen side. Unroll the drape all along the mounting arm (if using the cart, unroll along the cart). Position the transparent sheet in front of the screen; exact positioning will then be done automatically. Remove the open windows protection and throw it away immediately.

Alternatively, the surgeon may choose to use the mobile cart, which provides flexibility for height adjustments and mobility between cases. The cart's offset arm allows the GPS station to remain in the sterile field. Draping application and removal can be performed quickly.



Figure 1

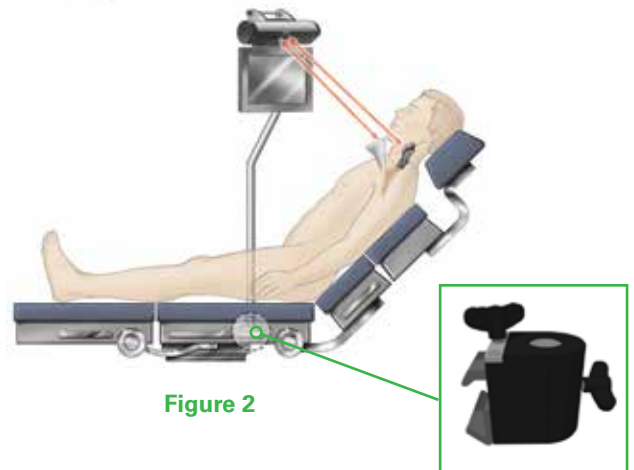

Figure 2

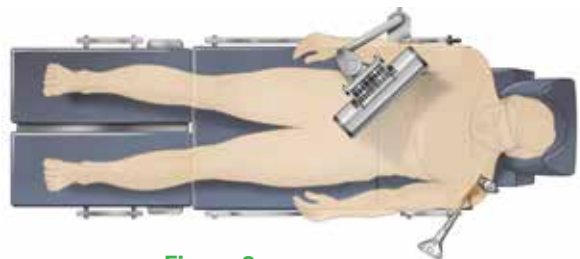

Figure 3

Note: When draping, it is helpful to adjust the head holder all the way back, and turn the patient's head to the contralateral side if possible. This helps to keep the drapes and intubation away from obstructing the view of the trackers. It can also be helpful to tape down the drapes around the patient's head.

Ensure the camera and station have line-of-sight to the incision to guarantee visibility throughout the technique (Figures 1-3).

Note: In a cold room or climate, start the station 30-45 min. in advance to ensure proper Tracker/camera visibility. When plugging in the station, first screw the power cable into the back of the station, then plug the other end of the power cable into the wall, and finally turn on the unit.

DETAILED STEPS PRIOR TO GPS

SURGICAL STEP - GLENOID PREPARATION

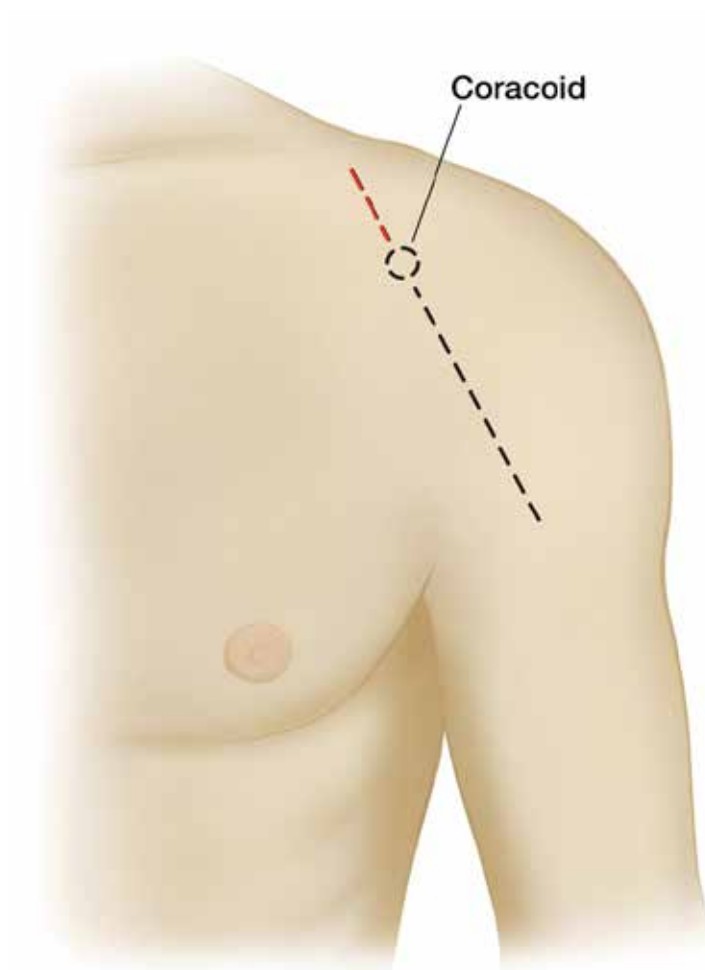

Figure 4

An anterior deltopectoral incision is made beginning inferior to the clavicle and passing over the coracoid process and extending distally toward the deltoid insertion (*Figure 4*). Medial and lateral subcutaneous flaps are created, and the deltopectoral interval is identified.

The position of the Tracker on the coracoid requires exposure of the coracoid bone. The incision should start 10mm proximal to the tip of the coracoid to guarantee exposure and minimize tissue tension throughout the case. The extended incision is required to minimize soft tissue force on the Tracker fixation throughout the case.

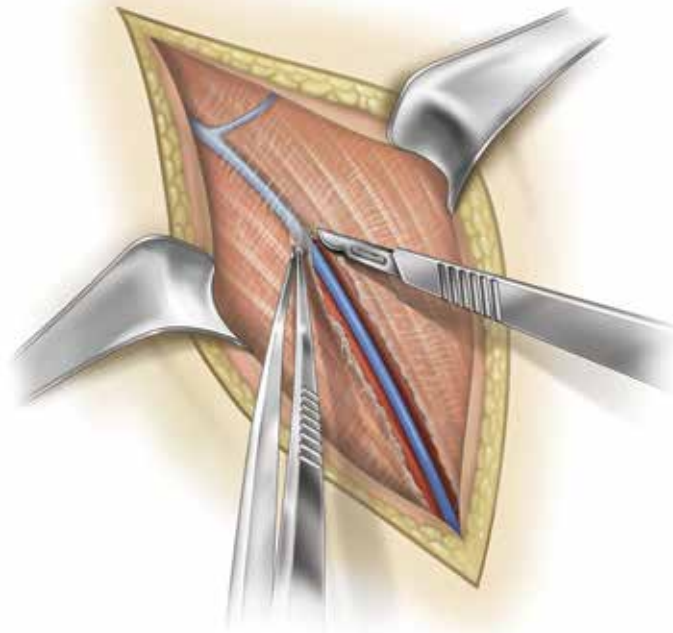

Figure 5

A thin fat stripe is usually located over the cephalic vein; the interval can be developed laterally depending on the surgeon's preference (*Figure 5*). Branches of the cephalic vein on the approach side are cauterized, and the interval is developed inferior to superior to expose the clavipectoral fascia.

The advantage of retracting the cephalic vein with the deltoid is the majority of the branches come from the deltoid. The disadvantage is the vein is more exposed to injury from the retractor as it crosses the superior aspect of the interval.

DETAILED STEPS PRIOR TO GPS

SURGICAL STEP - GLENOID PREPARATION

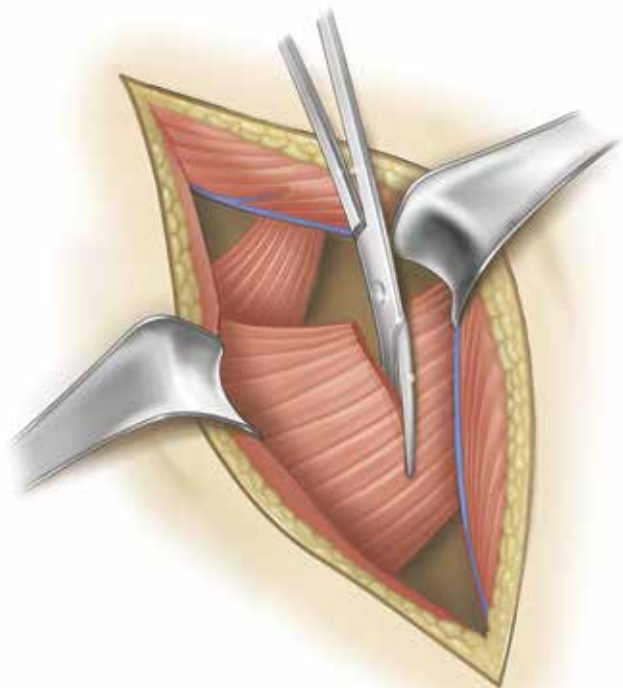

Figure 6

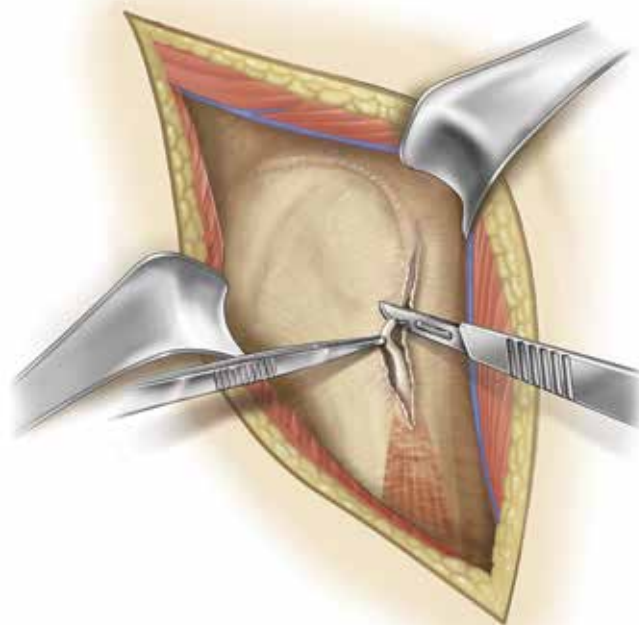

Figure 7

Resect the upper 1/3 of pectoralis tendon (*Figure 6*).

Tenodesis the biceps tendon (*Figure 7*).

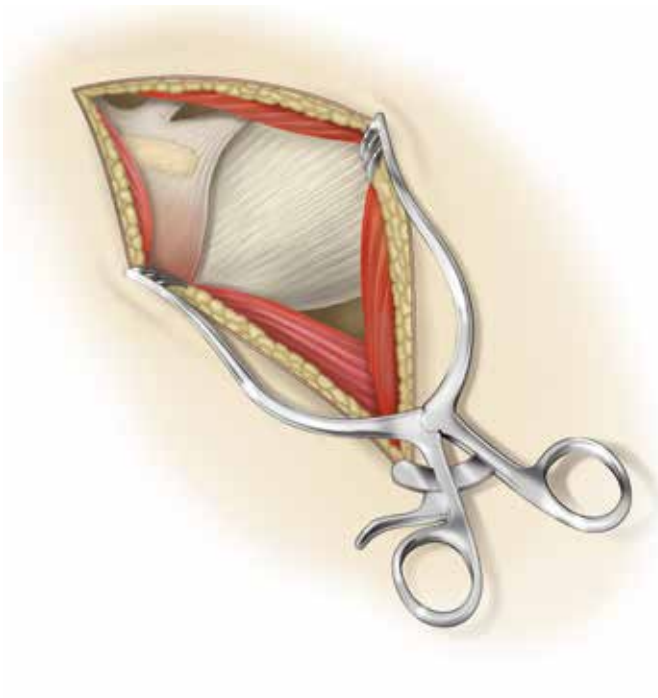

Figure 8

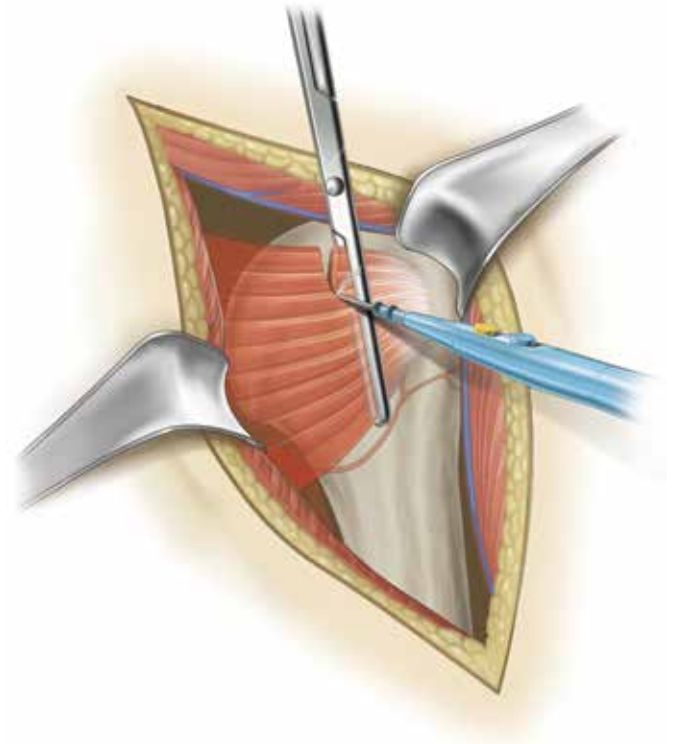

Figure 9

The subdeltoid space is mobilized with a blunt elevator. The clavicular head of the coracoacromial ligament (which is spared), and the conjoint tendon is mobilized. A self-retaining retractor is placed with care to avoid excessive traction on the conjoint tendon (*Figure 8*). The coracoacromial ligament is identified and the subacromial space is mobilized with a blunt elevator.

The subscapularis tendon insertion on the lesser tuberosity is identified along with the rotator interval. The anterior humeral circumflex vessels along the inferior border of the subscapularis muscle, the "three sisters," are cauterized extensively, and the biceps tendon is palpated in its groove (*Figure 9*). The subscapularis tendon and the capsule are tenotomized 1cm medial to the lesser tuberosity and tagged with #1 sutures.

An alternative approach is to elevate the subscapularis directly off the bone or elevate its insertion with a thin wafer of bone (1-2mm thick) using an osteotome. The choice is based on surgeon preference.

DETAILED STEPS PRIOR TO GPS

SURGICAL STEP - GLENOID PREPARATION

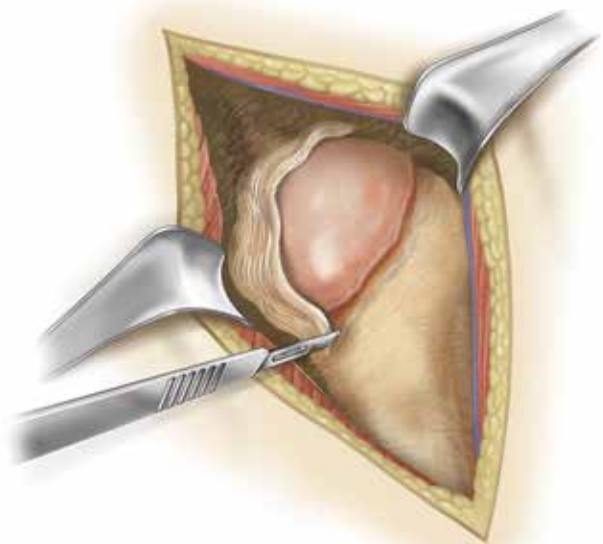

Figure 10

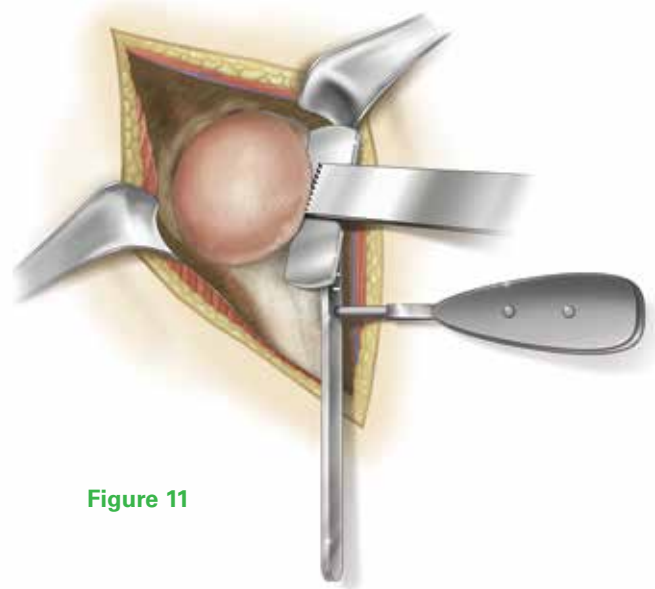

Figure 11

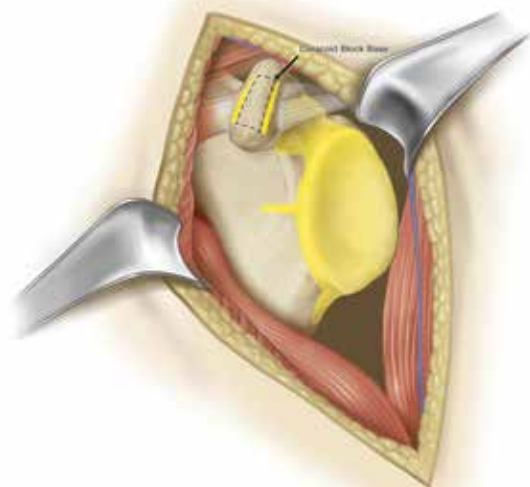

Figure 12

The rotator interval is divided in a lateral to medial direction up to the superior glenoid rim (*Figure 10*). With the humerus extended, adducted and externally rotated, the capsule is carefully dissected off the inferior humeral neck, protecting the axillary nerve inferiorly with a small blunt retractor placed just inferior to the capsule. The capsular releases should be performed to allow 90° of external rotation. The self-retaining retractor is then repositioned to retract the subscapularis. At this point, the humeral head can be dislocated.

Make the appropriate humeral head resection (*Figure 11*).

All areas in yellow must be exposed for acquisitions. All soft tissues and cartilage must be removed (*Figure 12*). Removal of the coracoacromial ligament is not required for acquisitions.

Note: Do not remove osteophytes or other bony landmarks before taking acquisitions, as these are necessary for proper use of the GPS system.

DETAILED STEPS PRIOR TO GPS

SURGICAL STEP - GLENOID PREPARATION

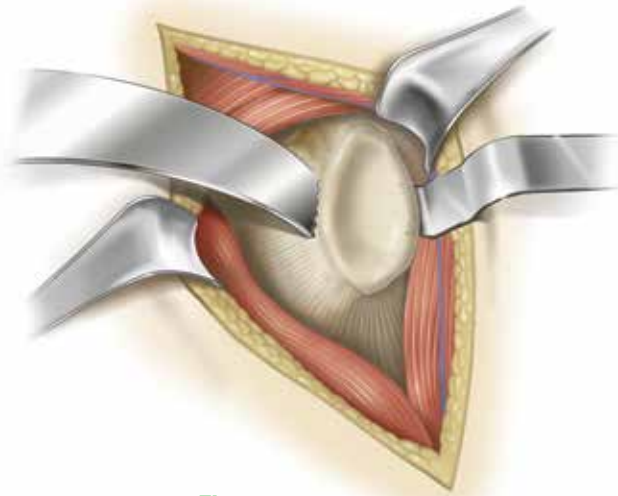

Figure 13

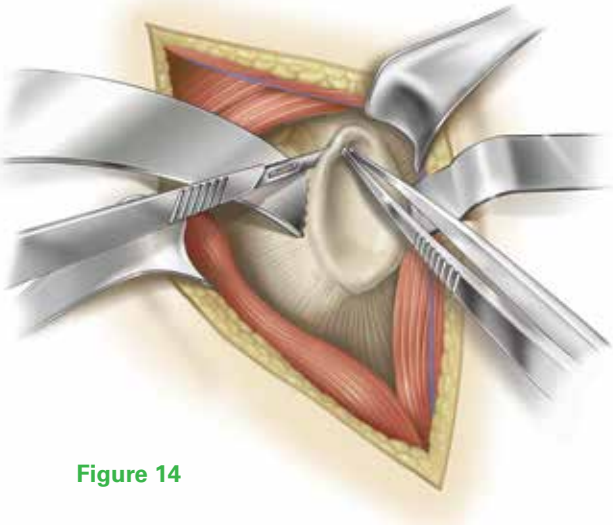

Figure 14

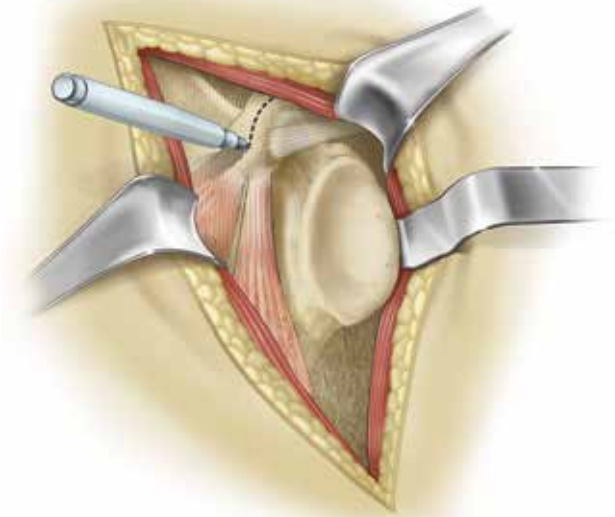

Figure 15

Place a retractor along the posterior border of the glenoid face (Figure 13) and retract the humeral head to expose the anterior glenoid edge. Dissect the anterior labrum (Figure 14).

Remove anterior labrum and capsule and clear soft tissue from glenoid face (Figure 15).

Carefully remove the hyaline cartilage from the glenoid surface using a Cobb elevator, ring curette, or comparable removal tool.

Note: It is critical to perform all the prep work on the humeral side (e.g. head resection) and extra glenoid exposure needed for the acquisition points before pinning the **Coracoid Block**. This is to minimize joint movement and risk of block fixation movement once the Coracoid Block has been pinned.

Continue exposing the glenoid by placing a blunt elevator under the subscapularis and releasing soft tissues attached to the anterior glenoid face. This will allow for better registration of the anterior glenoid border.

Some key steps to adequate glenoid exposure are as follows:

1. Fully mobilize subdeltoid space.
2. Release inferior capsule completely off the humerus while externally rotating the humerus.
3. Release anterior capsule and subscapularis from glenoid.
4. Excise labrum and release anterior and inferior capsule (protect axillary nerve).

DETAILED STEPS PRIOR TO GPS

SURGICAL STEP - GLENOID PREPARATION

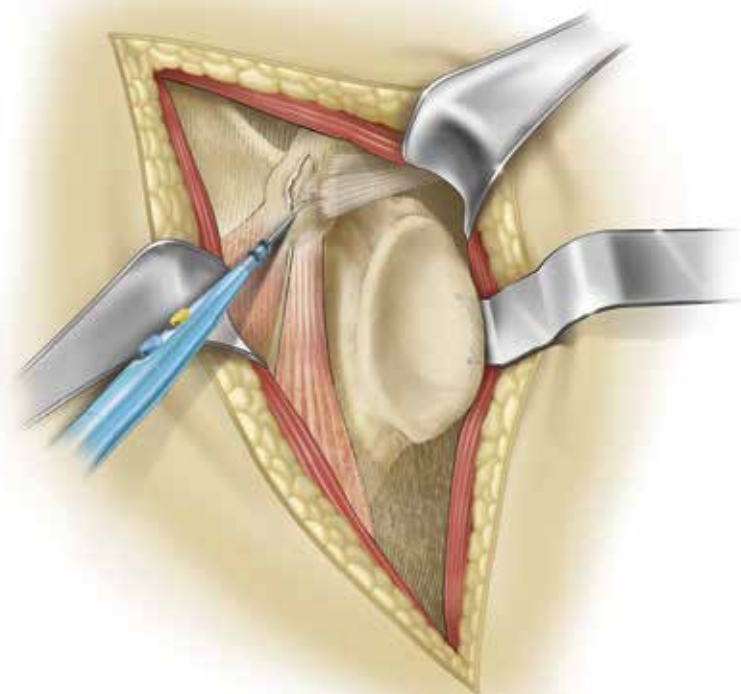

Figure 16

5. Resect adequate amount of humerus.
6. Stretch posterior capsule with humeral head retractor pushing humerus posterior to the glenoid.
7. If exposure is not adequate after steps 1-7, release posterior inferior capsule and triceps origin (must isolate and retract axillary nerve for this procedure).
8. If still poor exposure (very rare), then a posterior capsule release should be performed.

Clear fascia on superior coracoid using an electrocautery or blade (*Figure 16*). Using a marking pen or cautery, identify the axis of the coracoid.

It is important to note the short head of the biceps inserts near the tip of the coracoid and the pectoralis minor can wrap over the bone from the anterior side. Portions of these tissues may need to be removed to gain access to the bone.

Identify any soft tissue on the inferior portion of the coracoid and around the coracoid base. Remove this soft tissue.



Figure 17



Figure 18



Figure 19

Once the coracoid is exposed, the side-specific Tracker block should be affixed to the bone ensuring the Tracker post is oriented toward the camera. Note the camera can maintain visibility up to 160°, but more direct focus leads to better signal strength.

Note: For the first cases, extend the incision above the coracoid until it is determined how much exposure is needed for block placement.

Note: Before pinning the Coracoid Block, attach the G Tracker and hold the block up to where it will be pinned to the coracoid. This ensures Tracker visibility to the station before pinning, as it will not be able to be moved afterwards.

Coracoid anatomy can vary so make sure that the threaded coracoid pins have solid bone purchase with the first try. This

can be achieved by palpating or aiming with a small K-Wire through the posterior angled pin hole.

Step 1: Position the correct Coracoid Block on top of the coracoid so it is in line with the axis of the coracoid and so the trajectory of the screws will have good bone purchase, taking special care to ensure the posterior 30 degree angled pin will shoot down the base of the coracoid (Figure 17).

Step 2: Insert the short pin into the lateral slot in the block until hand tight. Aim for the middle of the slot so the block can self-adjust when the long pin is inserted (Figure 18).

Step 3: Insert the long pin into the medial hole of the block down the neck of the coracoid until hand tight. Carefully retighten pins, if necessary (Figure 19).

DETAILED STEPS PRIOR TO GPS

SURGICAL STEP - CORACOID BLOCK PLACEMENT



Figure 20



Figure 21

The block is now fixated and ready for Tracker attachment (Figures 20 and 21).

Note: If the bone quality is dense, it can help to pierce the top cortex on the coracoid through the block holes with a small 1.6mm K-Wire (no larger) before inserting the threaded pins.

Note: Screws should be tightened by hand (to confirm the G Tracker fixation).

Note: It is imperative to keep the coracoid block free of soft tissue tension throughout the case, and to keep a retractor behind it at all times. If there are assistants holding retractors, it is important to not let the tissue encroach on the base of

the block. It is a good idea to gently feel the fixation of the block throughout each navigated step, to ensure it is still robustly fixated.

Use a gelpi, or similar self-retaining retractor, vertically to keep the coracoid block free of soft tissue tension. The retractor can be clamped to the patient's head drapes to enable hands-free retraction.

Note: If robust fixation is not achieved the first time pinning the Coracoid Block to the bone, it is not advised to attempt repinning the block, creating additional holes in the bone.

DETAILED STEPS PRIOR TO GPS

CASE AND INSTRUMENT SELECTION



Figure 22

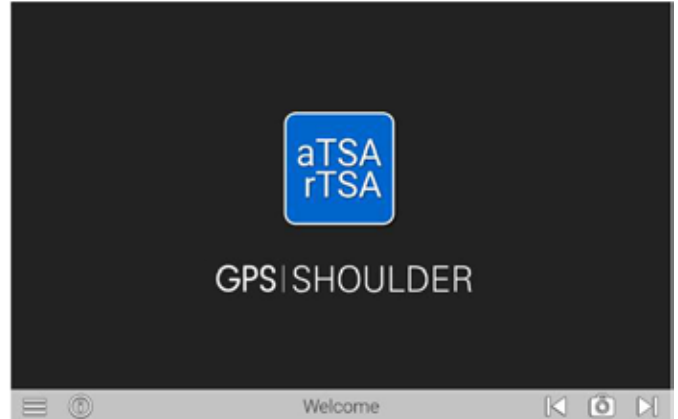

Figure 23

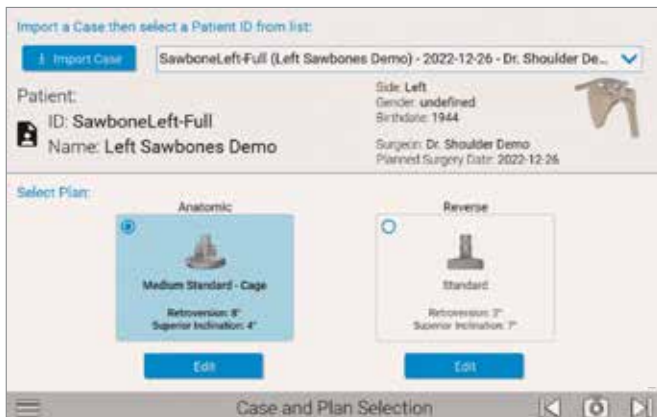

Figure 24

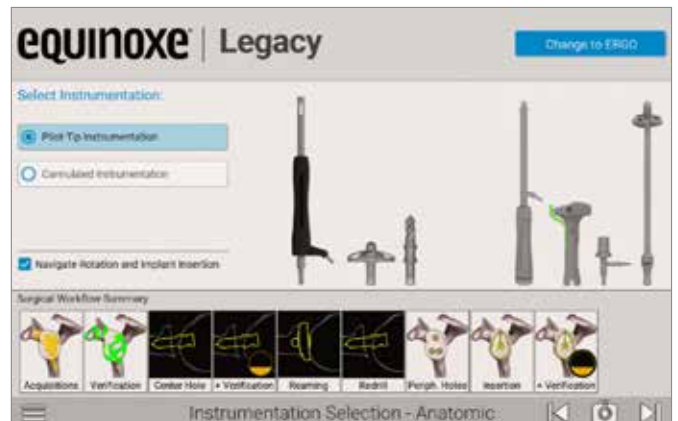

Figure 25

CASE AND PLAN SELECTION

Press the Shoulder Application icon on the GPS unit (*Figures 22 and 23*). If using a USB to transfer a case, on the Case and Plan Selection screen (*Figure 24*), select Import Case to import a case. If the case is already on the unit, click the box with the drop down and be sure to select the correct Patient ID. If using the AUGI App to transfer a case, once it is transferred, then click on the drop down menu and be sure to select the correct patient ID. Depending on what plans were exported, select the Anatomic or Reverse plans to navigate with GPS. Ensure the patient information displayed matches the patient in the OR.

Note: A plan can still be edited or created based on what was imported by pressing the Edit or Create button under the Anatomic or Reverse sections.

INSTRUMENTATION SELECTION

Next, on the instrumentation selection screen, verify the instrument set being used. If using Equinoxe Ergo GPS instruments, select the “change to Ergo button” at the top right of the screen. The “change to” button will only appear if your country has access to both Ergo and Legacy instruments (*Figure 25*).

Next, select the option for either Pilot Tip or Cannulated instrumentation. Surgeons may also select/unselect whether they will be using the rotation and implant impaction/insertion instruments and features. Note that some features require the use of the rotation and impaction steps.

Verify that the correct orientation of the station setup by reviewing the Station Setup screen after advancing.

DETAILED STEPS PRIOR TO GPS

CONNECTING TRACKERS



Figure 26

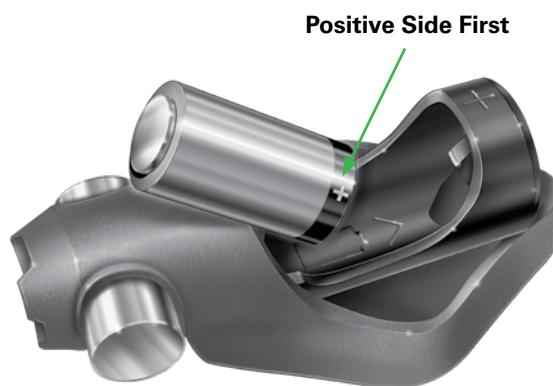

Figure 27

CONNECTING TRACKERS

The Seeking Tracker screen is displayed (Figure 26). Insert batteries, positive side first, into the three Trackers **Probe Tracker (P)**, **Glenoid Tracker (G)**, and **Tool Tracker (T)** (Figure 27).

Caution: Inserting negative side first or in reverse polarity may cause permanent damage to the Tracker.

Note: Use only the dedicated sterile batteries provided in the GPS kit. Do not reuse or sterilize the batteries.

Note: Alternatively, trackers can be connected in later screens prior to starting the procedure.

When the battery is properly inserted, a LED on each Tracker will illuminate solid red/orange then begin to blink green. Position the Trackers such that the LEDs face the GPS Unit. An audible tone will indicate when each Tracker connects to the GPS system. At the same time, the respective Tracker is highlighted on the Unit, and the LED illuminates solid orange. After the camera and three Trackers connect, the system will automatically advance to the next screen.

Note: In a cold room or climate, start the station 30-45 min. in advance to ensure proper Tracker/camera visibility.

Discard all used and unused batteries after completing the procedure.

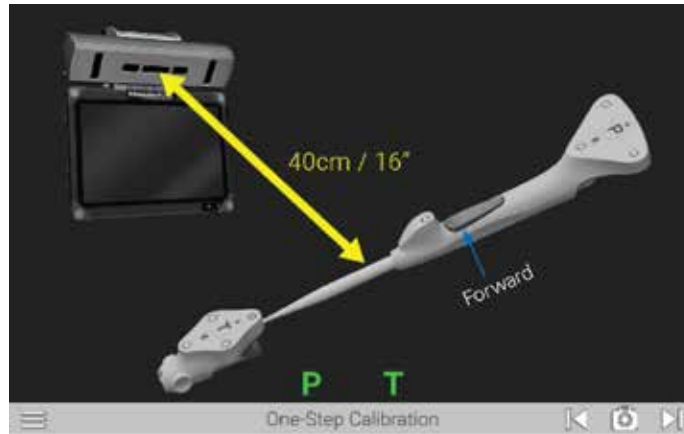

Figure 28



Figure 29

ONE-STEP CALIBRATION

Follow the onscreen prompts for calibrating the probe and Tracker. This step confirms that the probe’s readings are accurate.

The One-Step Calibration screen is displayed (Figure 28). Place the tip of the Probe Tracker (P) into the dimple node at the top of the T-Tracker. Hold both together **no more than** 16 inches (40 centimeters) from the display unit ensuring the white diodes are facing the camera.

When positioned correctly, the T and P status indicators on the display will appear green. Press the Forward button on the probe to initiate calibration. The progress bar will fill and an audible tone will indicate successful calibration. The system will automatically advance to the next screen.

Note: This is the only point of the operation where the surgeon will be required to hold the trackers this close to the screen.

Note: After pairing, the surgeon may attach the T-Tracker to the GPS Driver at this point. At any point in the procedure where a Tracker is attached to an instrument, test the physical connection every time by firmly tugging on the Tracker once it is attached. The Tracker will remain in place if it is properly attached.

FINAL CONFIRMATION

Once a case and instrument type have been selected, the surgeon will be shown a final confirmation screen that confirms the patient and preoperative plan. This now includes implant selection, planned version and inclination, implant location and % backside coverage. Be sure that all acquisitions must be performed **before** removing osteophytes (Figure 29).

DETAILED STEPS PRIOR TO GPS

PROBE ORIENTATION

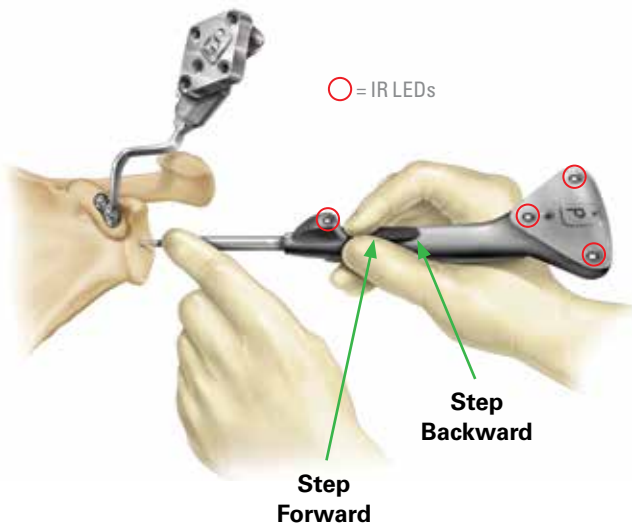

Figure 30a

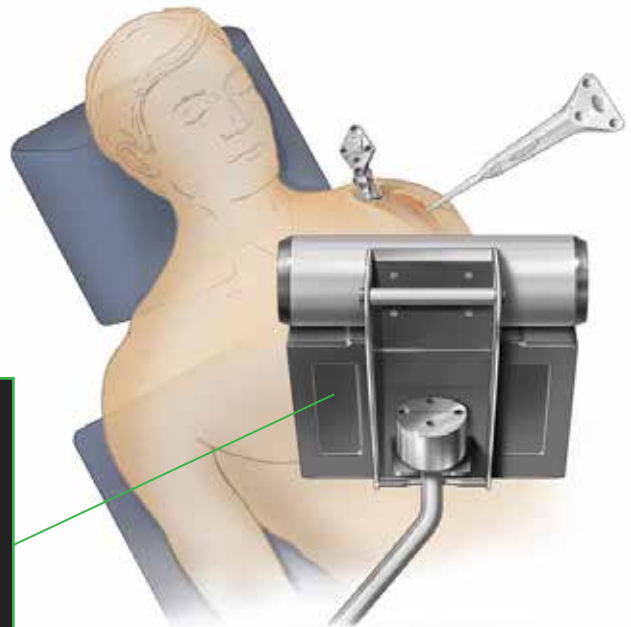

Figure 30b

PROBE ORIENTATION

Before beginning registration, ensure that the G Tracker is completely seated on the coracoid block. Press the Probe Tracker (P) with the index finger on the Forward button making sure not to obstruct the IR LED between the button and the probe tip (*Figure 30a*).

Always make sure the probe tip is on the anatomic landmark. Press and release the Forward button to begin registering acquisitions (*Figure 30b*).

For patch registration, place the probe tip on the anatomic landmark, **press and release** the Forward button ensuring the Probe is touching bone, **then** paint the anatomic reference shown on the screen using an S-like pattern. The button does not need to be held down for acquisitions.

Note: To return to previous step or re-do an acquisition, rapidly double click the Back button on the probe. The probe must be visible in order for the buttons to be selected.

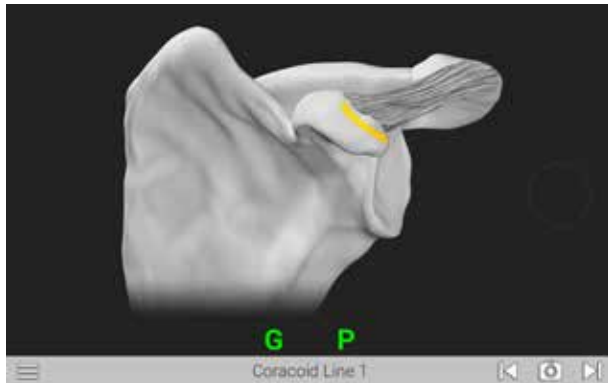

Figure 31a: Line anterior of coracoid block

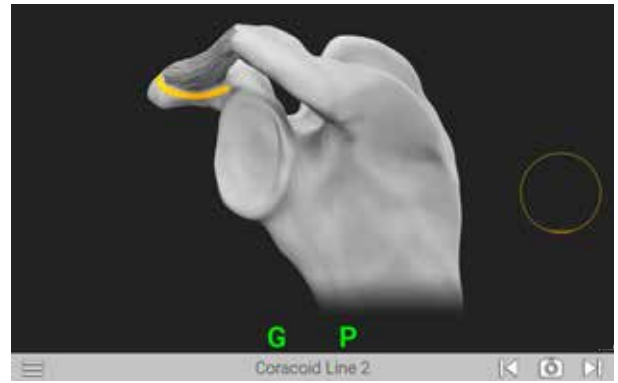

Figure 31b: Line posterior of coracoid block

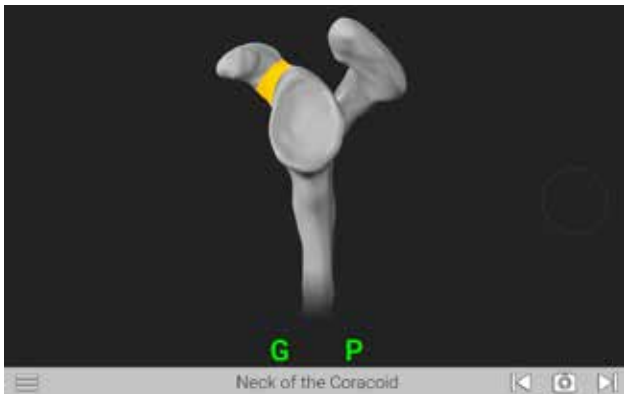

Figure 31c: Neck of coracoid

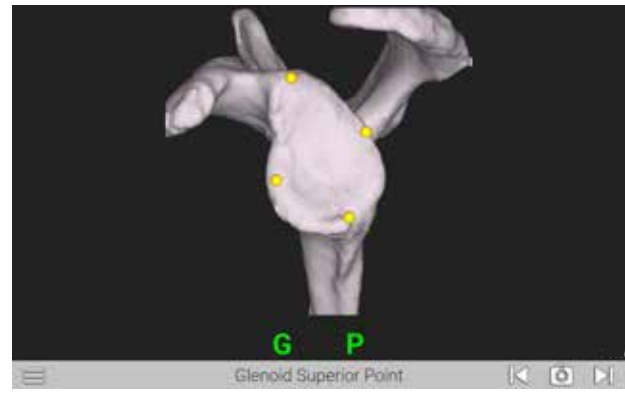

Figure 31d: Four points on glenoid face: superior, inferior, anterior, posterior

SURGICAL ACQUISITIONS

Using a two handed approach, probe the acquisition points listed on each screen as guided by the system (*Figures 31a-i*). When the probe tip is in contact with the bony area to be acquired, press the Forward button on the probe handle. The system will begin to acquire points as soon as the button is pressed. The button should not be held down to continue acquiring points, it only needs to be pressed once per step. Move the probe tip across the bony surface until the system has acquired enough points and moves to the next step. This can also be indicated by the circle to the right of the anatomy filling up and then turning green with a check mark. Take care to keep the probe in contact with bone the entirety of the acquisition process, and try to capture as much surface area as possible in each acquisition patch.

If the probe tip is lifted off or if incorrect points are acquired, the surgeon can re-do the acquisitions by clicking the Backwards button on the probe handle twice in succession.

On all points on the side walls of the glenoid face (inferior scapular neck, anterior lines), probe as medial on the bone as possible to aid in registration.

DETAILED STEPS PRIOR TO GPS

SURGICAL ACQUISITIONS

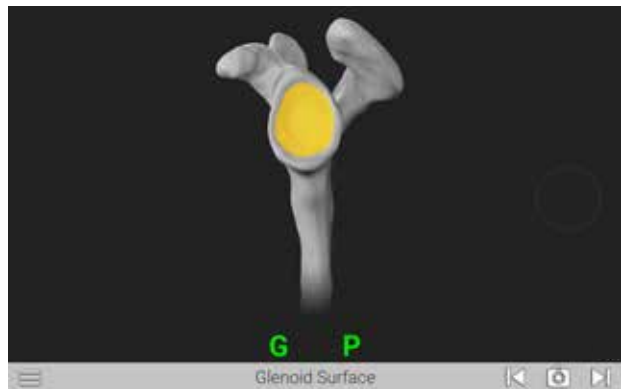

Figure 31e: Paint glenoid surface

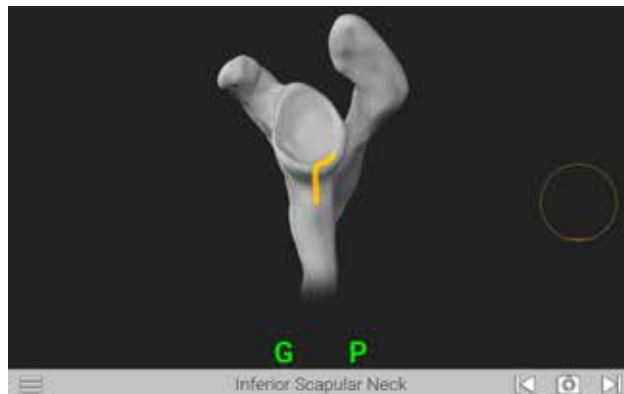

Figure 31f: Inferior glenoid neck

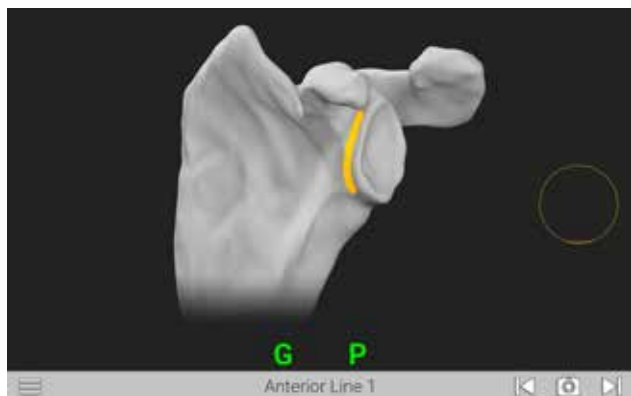

Figure 31g: Superior/Inferior line on scapular wall anterior of glenoid face

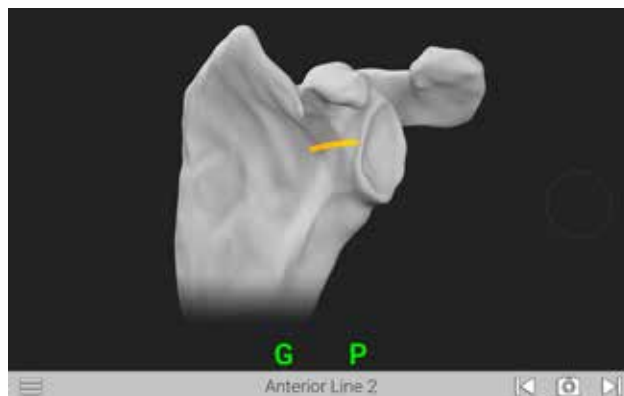

Figure 31h: Medial/Lateral line on scapular wall anterior of glenoid face

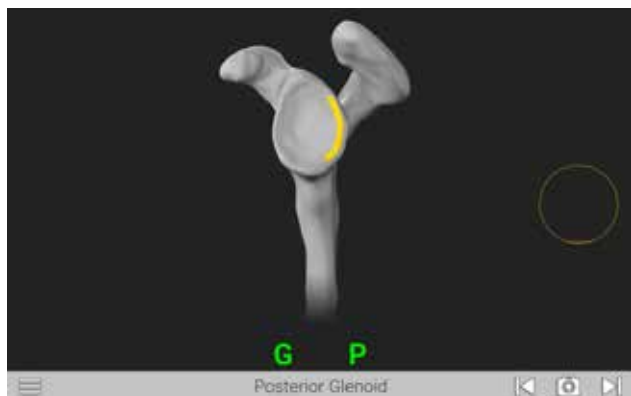

Figure 31i: Line on posterior face of glenoid

Note: Take care to sufficiently expose each acquisition area of all soft tissue and cartilage before probing points, so only bone is exposed and probed. Do not trim any osteophytes before taking acquisitions, even if they are a part of a specific acquisition area. The CT scan and 3D scapula model see only bone, so the surgeon must probe only bone for an accurate registration.

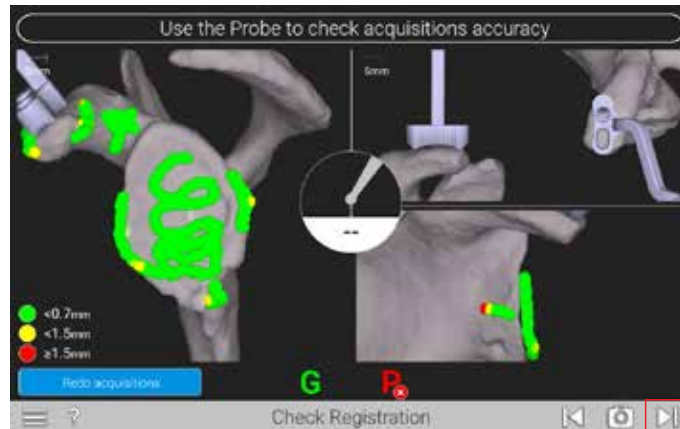

Figure 32a

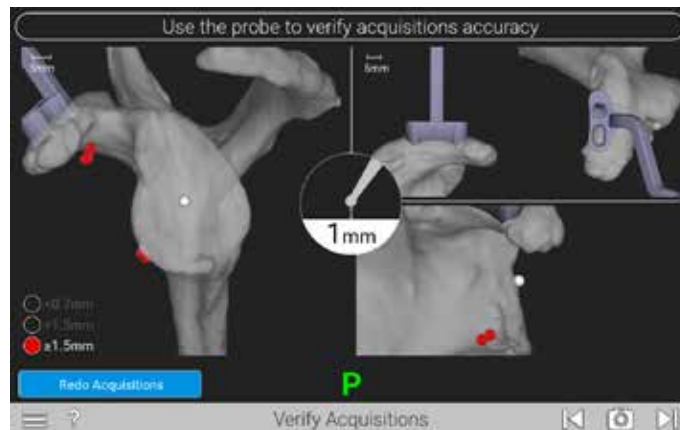

Figure 32b

The system will digitize the acquisitions and generate a color map of the points for verification (Figure 32a).

- Green points signify that acquired points match digital reconstruction within .7mm or less.
- Yellow points signify that acquired points vary from .7 to 1.5mm from digital reconstruction.
- Red points signify that acquired points vary more than 1.5mm from the digital reconstruction.

Surgeons should strive for all green points in the digitization. It is important to identify which acquisition areas may be inaccurate based on the color and locations of the points. For example, if there is a trail of yellow and red dots at the end of an acquisition area that extends off the surface of the bone, assume that the probe tip was lifted off of the bone surface

before all points were acquired, and points were acquired in empty space.

Once all acquisitions obtained are green, the surgeon may verify accuracy by spinning around the scapula via the screen. This can also be achieved by using the mouse, clicking and then rotating the scapula. If acquisitions are accurate enough, an advance arrow will appear at the bottom right.

Surgeon may press on the color indicators on the bottom left to filter their view to the specific points acquired, as shown on Figure 32b.

Note: Use the probe tip to touch different surfaces on the scapula to see the probe tip show up on the screen; this will verify the probe is registering where the surgeon is physically touching the bone.

DETAILED STEPS PRIOR TO GPS

VERIFY AQUISITIONS

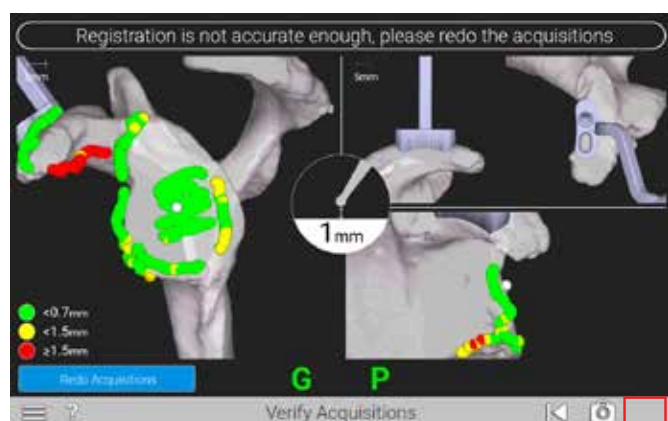

Figure 33

If acquisitions are not accurate enough to continue, the "Advance" button will be missing on the bottom right of the screen, as seen in the top image of (Figure 33). Using the Verify Acquisitions screen, identify which acquisitions need to be re-done based on the color map of the acquisitions.



Figure 34

To continue re-doing acquisitions, select "Re-do" and then select the landmarks to re-do (Figure 34).

Note: If there are several areas where the acquisition map is red, select the Select All button to re-do all acquisitions.

DETAILED OPERATIVE TECHNIQUE

LEGACY ANATOMIC SHOULDER



Figure 35

STEP 1: CENTER HOLE DRILL

Once registration is completed, attach the T-Tracker onto the **GPS Driver (531-25-00)**. Then attach the GPS Center Drill to prep the central peg for the glenoid hole (*Figure 35*).

Before attaching the center drill, attach the T-Tracker onto the GPS Driver. Ensure the tracker is fixated on the tracker post with the tracker face aiming in the direction of the pilot tip of the driver.

Note: It is helpful to utilize a “tug test” both rotationally and vertically to ensure the tracker is properly fixated on the instrument and to ensure it does not move.

Note: At any point in the procedure, the surgeon may use the probe to advance to the next screen by pressing the forward button twice while facing the camera.

WARNING: Don't assemble or disassemble devices in the surgical field.

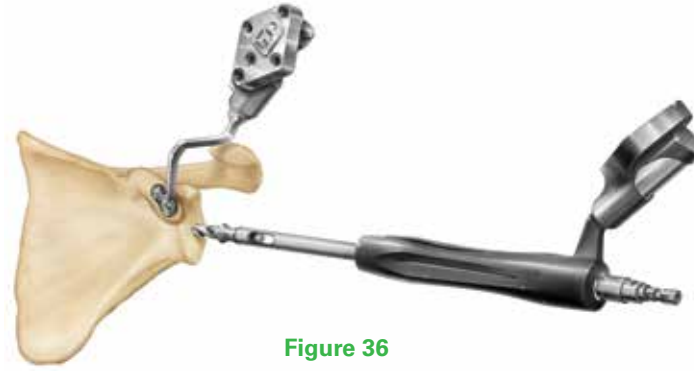

Figure 36

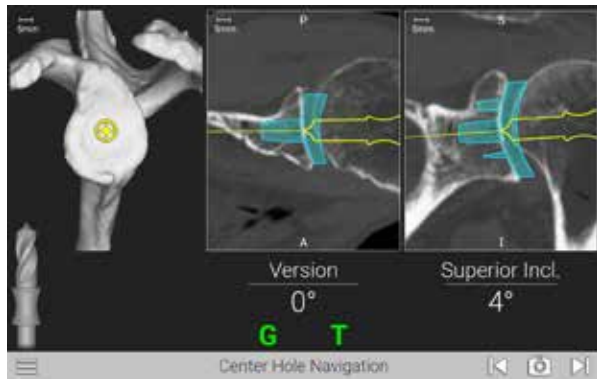

Figure 37a

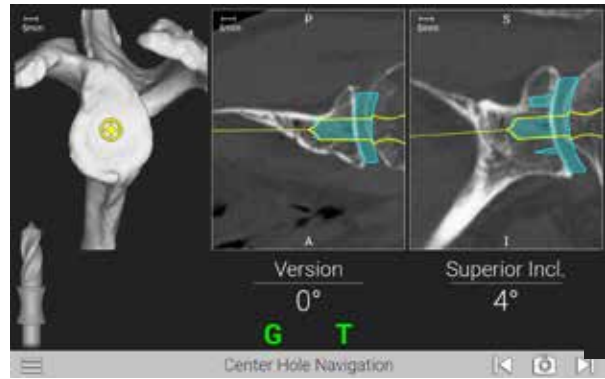

Figure 37b

	Implant	Implant Length (mm)	Drill to Use	Drill Flute Length (mm)	Overdrill Amount (mm)
ANATOMIC	Cage Glenoid	14.5	531-27-60 (GPS)	18.7	4.2
	Cage Glenoid - 8° Augment	15.9	531-27-60 (GPS)	18.7	2.8
	Laser Cage Glenoid	14.6	531-27-60 (GPS)	18.7	4.1
	Laser Cage Glenoid - 8 degree Augment	15.9	531-27-60 (GPS)	18.7	2.8
	Pegged Glenoid - Standard	11.7	531-27-60 (GPS)	18.7	7.0
	Pegged Glenoid - 8° Posterior Augment	11.6	531-27-60 (GPS)	18.7	7.1
	Pegged Glenoid - 16° Posterior Augment	12.2	531-27-60 (GPS)	18.7	6.5
	Keeled	16	531-27-60 (GPS)	18.7	2.7

Note: Not all instruments and implants are available in every market.

Use the GPS Driver to drill the glenoid center hole (Figure 36). Follow the on-screen guidance to orient the GPS Driver according to the plan.

- For positioning of the drill, the tip of the drill is indicated by a yellow dot.
- The planned position is indicated by a blue dot.

Note: Avoid applying a bending force to the GPS Driver or using the GPS Driver to retract the humeral head as this may cause fracture of the 2mm K-Wire or pilot tip reamer.

The orientation is guided by the circular cross-hair indicator. When the target is perfectly aligned, the screen will display the cross-hair superimposed on the yellow dot (Figures 37a and b).

Note: The numbers shown for version and inclination are displayed according to the preoperative plan.

The plan may not necessarily read 0° version and 0° inclination. The surgeon may deviate from this plan if desired. This screen includes an image of the orientation that is synchronized with the CT scan slices to visualize the cortices.

DETAILED OPERATIVE TECHNIQUE

LEGACY ANATOMIC SHOULDER

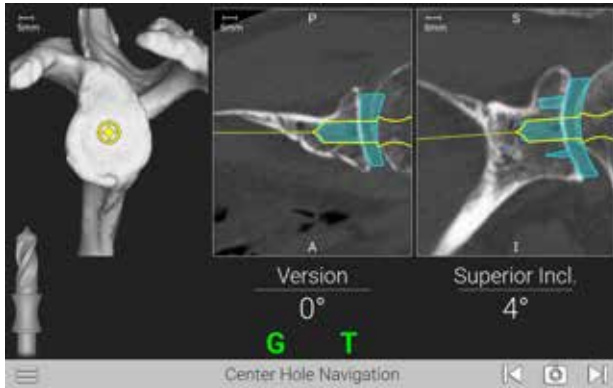

Figure 38a

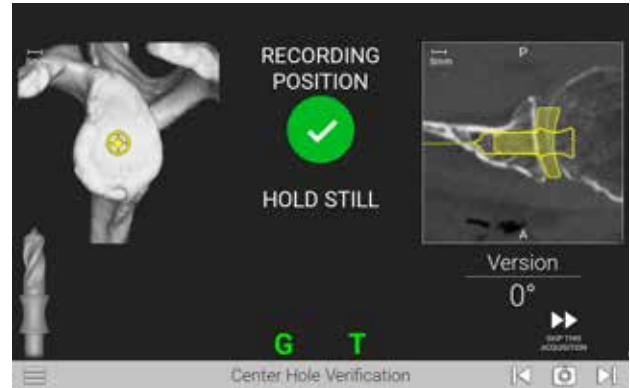

Figure 38b

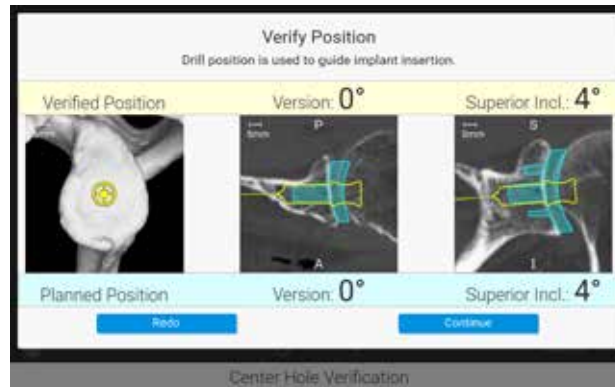

Figure 39

Drill the center cage hole for the Anatomic Glenoid Implant using the on-screen guidance. Once the drill is fully seated, the surgeon may advance to the next screen but **do not take the drill out of the bone** (Figure 38a).

Note: At any point in the procedure, the surgeon may use the probe to advance to the next screen by pressing the forward button twice while facing the camera.

VERIFY POSITION

With the drill still fully seated in the bone, hold the Driver in place over the drilled axis to capture the position of the planned implant. The system will adjust the original plan to where the drill was actually placed. The system will advance to the next step automatically, accurately recording the drill axis location and orientation (Figure 38b).

A pop-up will appear showing the verified position of the drill vs. the planned position. If the surgeon would like to re-do the digitization, press Re-do. If the surgeon accepts the digitization, press Continue (Figure 39).



Figure 40a



Figure 40b

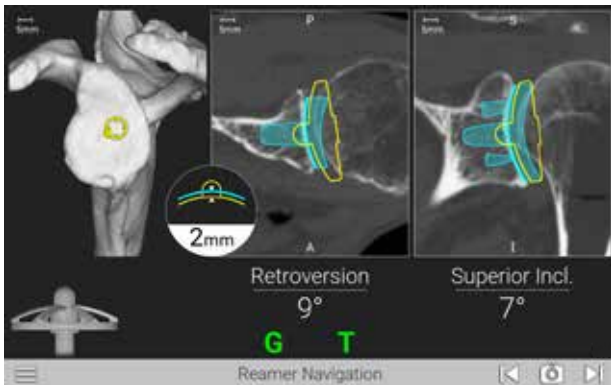

Figure 41a

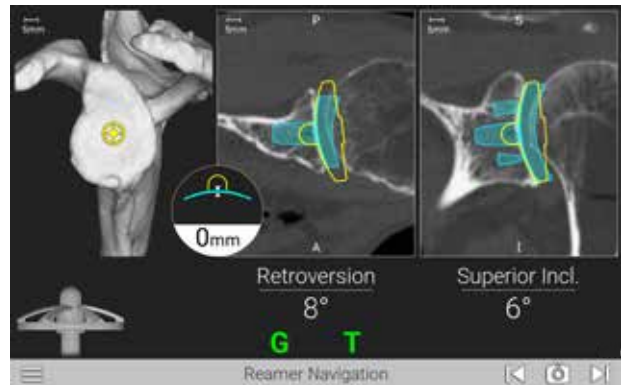

Figure 41b

STEP 2: GLENOID REAMING

Select a **Anatomic Nubbed Reamer** per Equinox® surgical technique (OPTECH-000204) and attach to the **GPS Driver** (Figures 40a and 40b).

Follow the on-screen guidance to ream according to the plan (Figures 41a and 41b). The reaming screen is guided in a similar fashion to the pilot-hole guidance, with real-time feedback on the position of the pilot-tip and reamer curvature relative to the planned depth.

Press the Next arrow to proceed and detach the reamer.

Note: When preparing for augmented glenoid components, be aware that the drilling axis is different from the reaming axis. The system accounts for this; the surgeon does not need to adjust for this mismatch.

DETAILED OPERATIVE TECHNIQUE

LEGACY ANATOMIC SHOULDER

LEGACY ANATOMIC SHOULDER

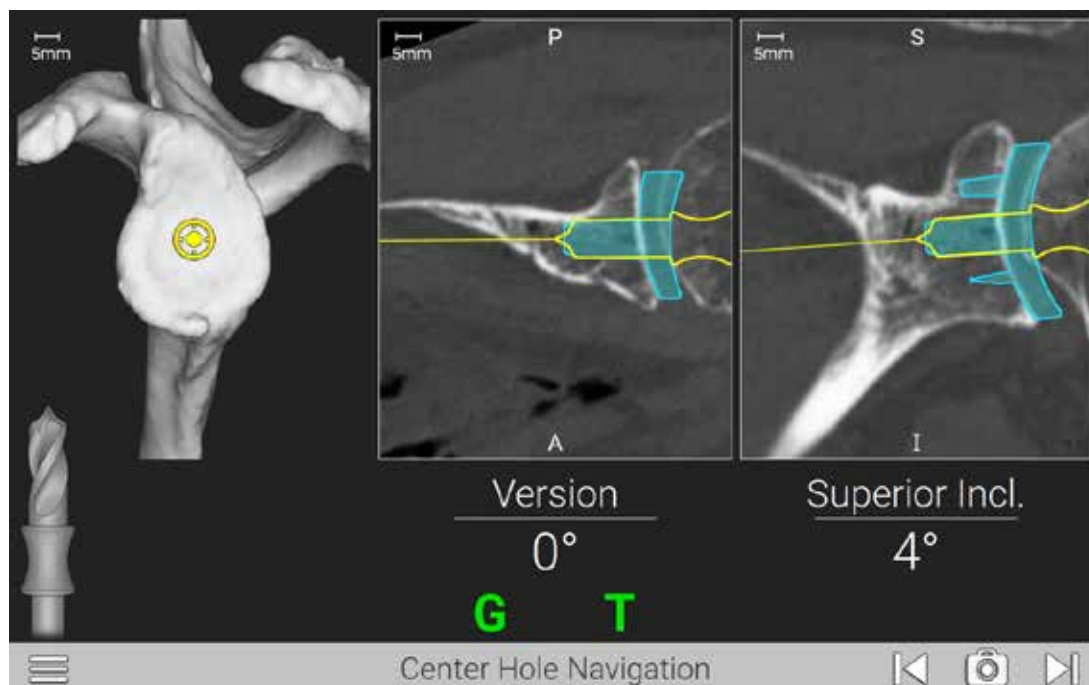

Figure 42

POTENTIAL RE-DRILL

If the surgeon reams more than 2mm of glenoid bone, re-attach the center drill to the GPS Driver and re-drill the center hole to ensure proper depth for implant seating (Figure 42).



Figure 43



Figure 44

STEP 3: PERIPHERAL PEG DRILL

Remove the T-Tracker from the **GPS Driver** and attach it to the **Zimmer-Hudson Adapter (301-09-80)**. Ensure the Tracker is facing the direction of the indicated shoulder with the laser marking on the post under the Tracker (i.e. left for left, right for right).

Note: It is helpful to utilize a “tug test” both rotationally and axially to ensure the tracker is properly fixated on the instrument and to ensure it does not move.

Attach the male end of the Zimmer-Hudson adapter to the Zimmer-Hudson handle, and the female end of the Zimmer-Hudson adapter to the appropriate **Peripheral Peg Drill Guide** for the planned anatomic glenoid implant, with the drill guide size marking reading right side up in the direction of the Tracker. Ensure that the drill guide bottoms-out and fully engages with the Zimmer-Hudson Adapter, and that the collar of the Zimmer-Hudson Adapter fully deploys over the male end of the Zimmer-Hudson drill guide (Figure 43).

Next, attach the **Peripheral Peg Drill (315-27-63 in the Ergo Conventional Instruments Tray)** to the GPS Driver (Figure 44).

DETAILED OPERATIVE TECHNIQUE

LEGACY ANATOMIC SHOULDER

LEGACY ANATOMIC SHOULDER



Figure 45a

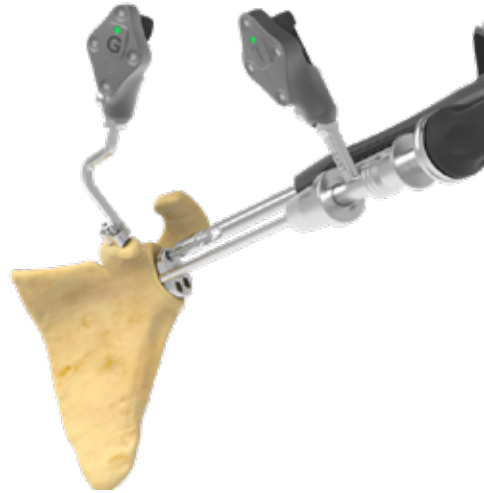

Figure 45b

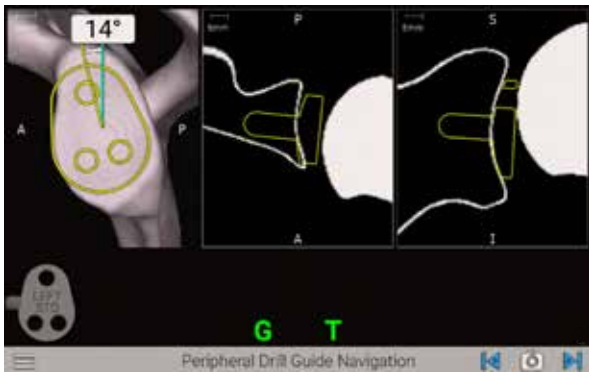

Figure 46a

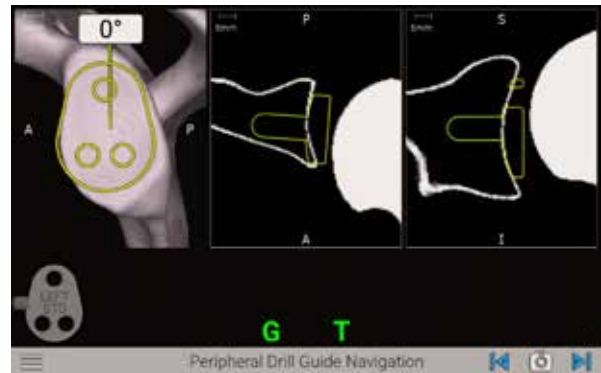

Figure 46b

With one hand, hold the Peripheral Drill Guide and Zimmer-Hudson Adapter assembly with the T-Tracker attached. With the other hand, insert the Peripheral Peg Drill into the Peripheral Peg Drill Guide (Figures 45a and 45b).

Use the angle measurement on the screen to adjust the Peripheral Peg Drill Guide to the plan (Figure 46a).

The surgeon will want to rotate the Peripheral Peg Drill Guide to match the yellow line with the blue line. The degrees shown on screen represent the variability of the angle to plan, **not the overall planned rotation of the implant** (Figure 46b).

Drill each of the 3 peripheral peg holes, then remove all drills with guide. When finished drilling peripheral peg holes, remove the tools and advance the screen.



Figure 47a

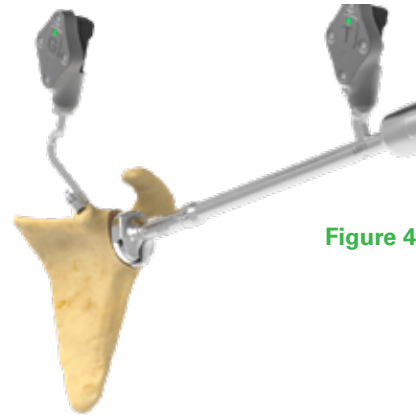

Figure 47b

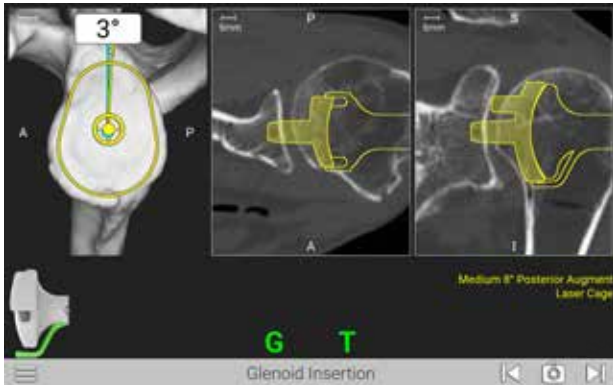

Figure 48a

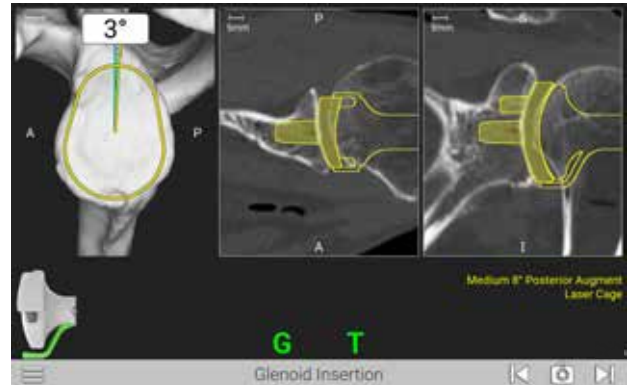

Figure 48b

STEP 4: IMPLANT INSERTION

Attach the appropriate anatomic **Glenoid Inserter Impactor Tip** to the **GPS Impactor Handle (531-07-05)**. After removing the T-Tracker from the Zimmer-Hudson Adapter from the prior step, place it onto the GPS Impactor Handle, again ensuring left for left, right for right (*Figures 47a and b*).

Note: It is helpful to utilize a “tug test” both rotationally and vertically to ensure the tracker is properly fixated on the instrument and to ensure it does not move.

Only Equinox Ergo Impactor Tips are compatible (315-54 02/03/04/05 and 315-55-02/03/04/05).

Use the onscreen prompts to place and impact the implant according to the plan (*Figures 48a and 48b*). The screen will indicate the implant being impacted and it will show the corresponding color inserter to use for that specific implant.

Again, the degrees shown on screen represent the variability of the angle to plan, not the overall planned rotation of the implant. Once implant is fully seated, **do not remove the impactor and inserter**.

Note: Ensure the superior portion of the implant is always oriented in the same direction as the Tracker.

WARNING: Don't assemble or disassemble devices in the surgical field.

DETAILED OPERATIVE TECHNIQUE

LEGACY ANATOMIC SHOULDER

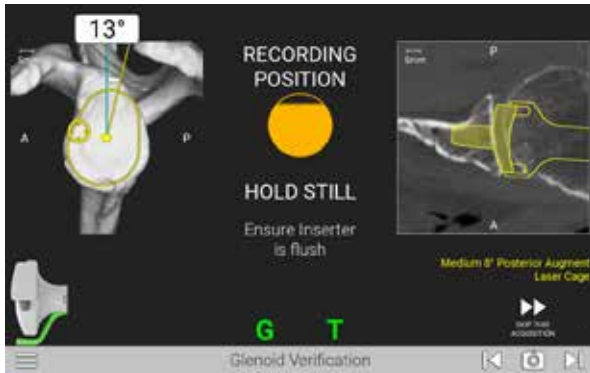

Figure 49a

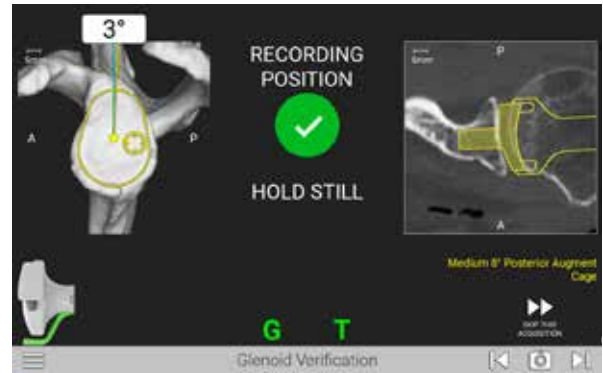

Figure 49b

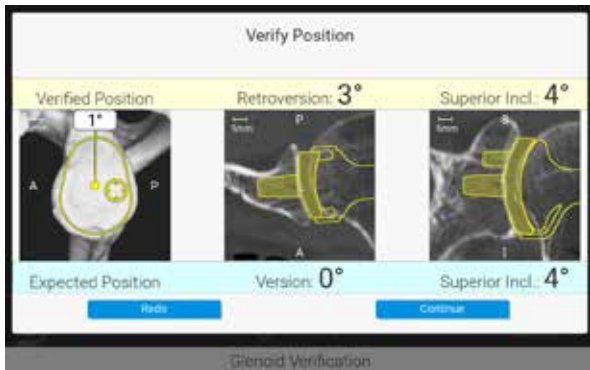

Figure 50

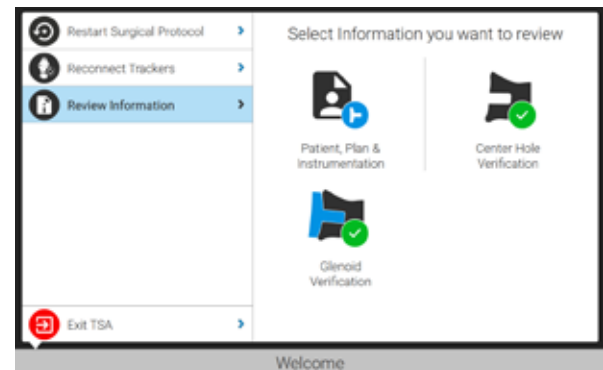

Figure 51

VERIFY POSITION

After implanting, hold the Impactor Handle and ensure the Inserter is still and flush against the implant face (Figure 49a). Press the Next button on the screen to capture the position of the implant placement (Figure 49b).

A pop-up will appear showing the verified position of the implant vs. the planned position. If the surgeon would like to redo the digitization, press Re-do (Figure 50). If the surgeon accepts the digitization, press Continue to capture the verified implant placement. Once the navigated part of the procedure is complete, remove the G Tracker and Coracoid Block.

Complete remaining surgical steps per Equinox Ergo surgical technique. At the end of the case, the sales representative will run GetStationLog on the GPS system to upload the case. Make sure to upload all cases to AI One. Case reports showing the final verified implant placement are available on the surgeon's AI One account.

Note: You can always review the plan by pressing the menu button and selecting "Review Information" from the pop-up menu on the left (Figure 51).

DETAILED OPERATIVE TECHNIQUE

LEGACY REVERSE SHOULDER



Figure 52

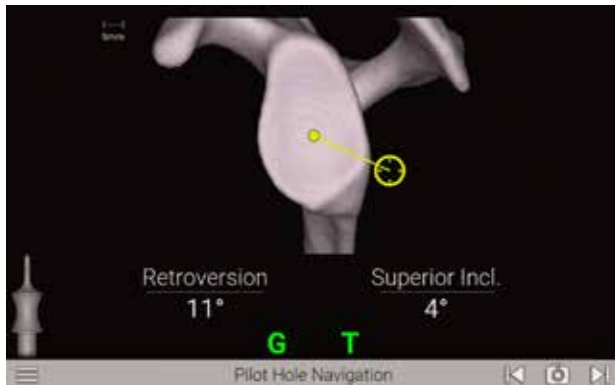

Figure 53a

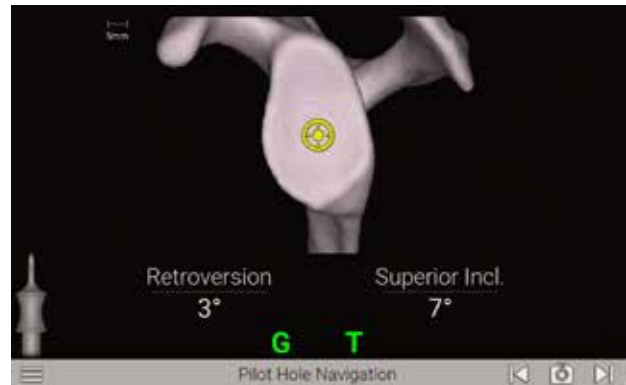

Figure 53b

STEP 1: PILOT TIP DRILL

Once registration is completed, attach the **2.0mm Drill (included in the sterile packed KIT 531-20-00)** to **GPS Driver (531-25-00)** create the pilot hole for reaming (Figure 52).

Follow the on-screen guidance to place the components according to the plan. Both the pilot hole and K-Wire insertion screens are guided in a similar fashion with real-time feedback on the position of the Driver (Figure 53a).

Note: Avoid applying a bending force to the GPS Driver or using the GPS Driver to retract the humeral head as this may cause fracture of the pilot tip drill.

Note: The numbers shown for version and inclination are displayed according to the preoperative plan.

Note: The plan may not necessarily read 0° version and 0° inclination. The surgeon may deviate from this plan if desired.

This screen includes an image of the orientation that is synchronized with the CT scan slices to visualize the cortices.

- For positioning of the Drill, the tip of the Drill is indicated by a yellow dot.
- The planned position is indicated by a blue dot.

The orientation is guided by the circular crosshair indicator. When the target is perfectly aligned, the screen will display the crosshair superimposed on the yellow dot. Follow the on-screen guidance to drill the center (Figure 53b).

Note: Avoid applying a bending force to the GPS Driver or using the GPS Driver to retract the humeral head as this may cause fracture of the pilot tip feature.

WARNING: Don't assemble or disassemble devices in the surgical field.



Figure 54a



Figure 54b

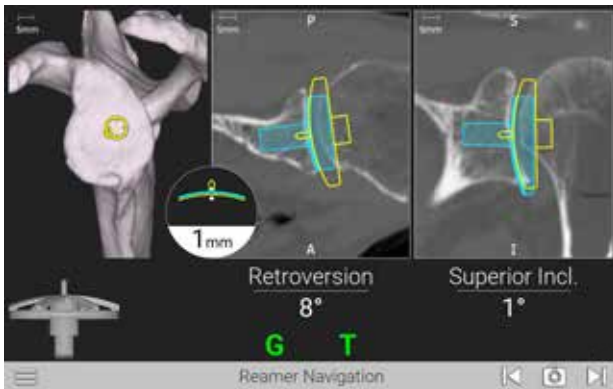

Figure 55a

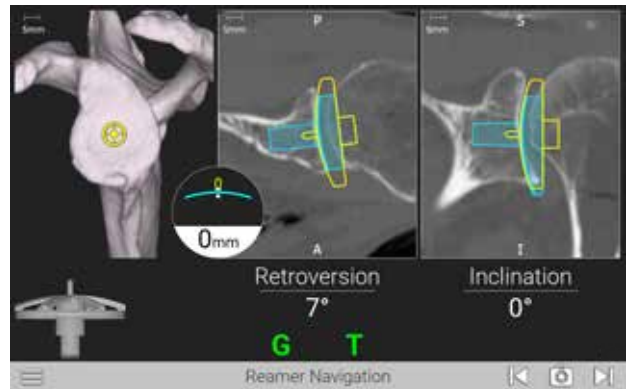

Figure 55b

STEP 2: GLENOID REAMING

Select a **Reverse Pilot Tip Reamer** per Equinox surgical technique (OPTECH-000204) and attach to the GPS Driver (Figures 54a and 54b).

Follow the on-screen guidance to ream according to the plan (Figures 55a and 55b). The reaming screen is guided in a similar fashion to the pilot-hole guidance, with real-time feedback on the position of the pilot-tip and reamer curvature relative to the planned depth. Press the Next arrow to proceed and detach the reamer.

Note: When preparing for augmented glenoid components, be aware that the drilling axis is different from the reaming axis. The system accounts for this; the surgeon does not need to adjust for this mismatch.

DETAILED OPERATIVE TECHNIQUE

LEGACY REVERSE SHOULDER



Implant	Implant Length (mm)	Drill to Use	Drill Flute Length (mm)	Overdrill Amount (mm)
Standard Glenoid Plate	16.6	531-27-60 (GPS)	18.7	2.1
10° Superior Augment Glenoid Plate	18.3	531-27-60 (GPS)	18.7	0.4
8° Posterior Augment Glenoid Plate	16.8	531-27-60 (GPS)	18.7	1.9
10mm Extended Cage Glenoid Plate	26.6	315-27-60 (Legacy Equinox)	24.7	-1.9*
Superior Posterior Augment Glenoid Plate	23.3	315-27-60 (Legacy Equinox)	24.7	1.4
Small Standard Glenoid Plate	13.1	531-27-60 (GPS)	18.7	5.6
Small 10° Superior Augment Glenoid Plate	14.3	531-27-60 (GPS)	18.7	4.4
Small 8° Posterior Augment Glenoid Plate	13.9	531-27-60 (GPS)	18.7	4.8
Small 10mm Extended Cage Glenoid Plate	23.1	315-27-60 (Legacy Equinox)	24.7	1.6
Small Superior Posterior Augment Glenoid Plate	17.9	531-27-60 (GPS)	18.7	0.8

Standard Baseplate
Small Baseplate

Note: Not all instruments and implants are available in every market.

*All center drills for GPS are used without a drill guide. Drill into native glenoid bone first, and then add the graft and drill into the graft, as the drill is short. Alternatively, chase the hole with the 315-15-38 extended drill.



Figure 56a



Figure 56b

STEP 3: CENTER DRILL

Attach the corresponding **Center Cage Drill Bit** to the **GPS Driver** (Figure 56a). Be sure to use the correct drill based on the implant being used. Refer to the chart above.

Drill the center cage hole for the **Reverse Glenoid Baseplate** (Figures 56b). Once the drill is fully seated, the surgeon may advance to the next screen, **but do not take the drill out of the bone.**

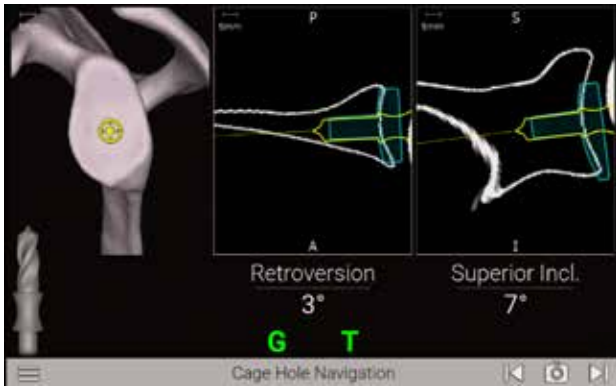

Figure 57a



Figure 57b

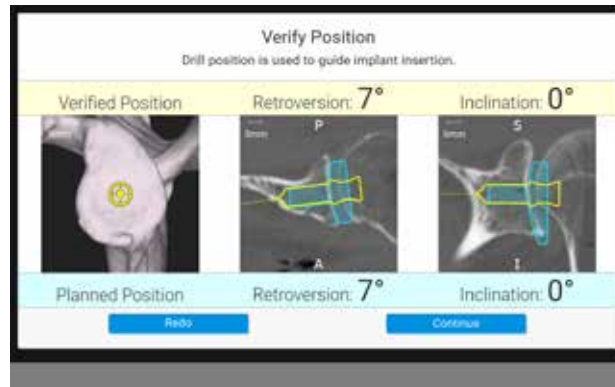

Figure 58

VERIFY POSITION

With the drill still fully seated in the bone, hold the **GPS Driver** in place over the drilled axis to capture the position of the planned implant. The system will adjust the original plan to where the drill was actually placed (*Figures 57a and 57b*).

The system will advance to the next screen automatically, accurately recording the drill axis location and orientation.

A pop-up will appear showing the verified position of the drill vs. the planned position (*Figure 58*). If the surgeon would like to re-do the digitization, press Re-do. If the surgeon accepts the digitization, press Continue.

DETAILED OPERATIVE TECHNIQUE

LEGACY REVERSE SHOULDER

LEGACY REVERSE SHOULDER

Baseplate Inserter Chart

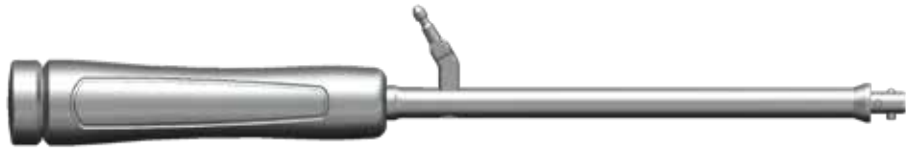

GPS Impactor Handle

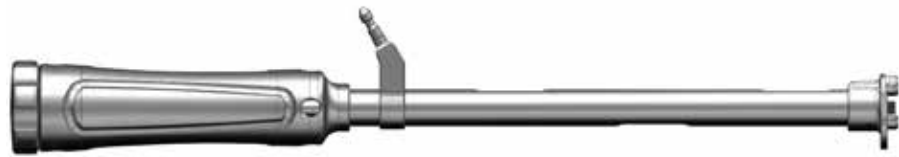

GPS Reverse Inserter Handle

Figure 59

Figure 60

GPS Impactor Handle
Compatible Baseplate Inserters



321-19-13 – Ergo Inserter (Pilot)



321-19-14 – Ergo Inserter



321-35-23 and 321-35-24 –
Ergo Small Reverse Baseplate Inserter

Superior

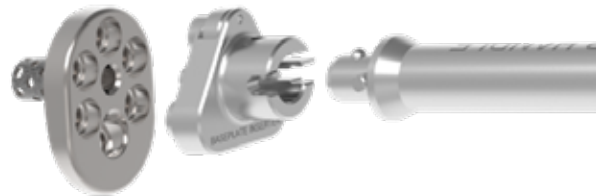

Inferior

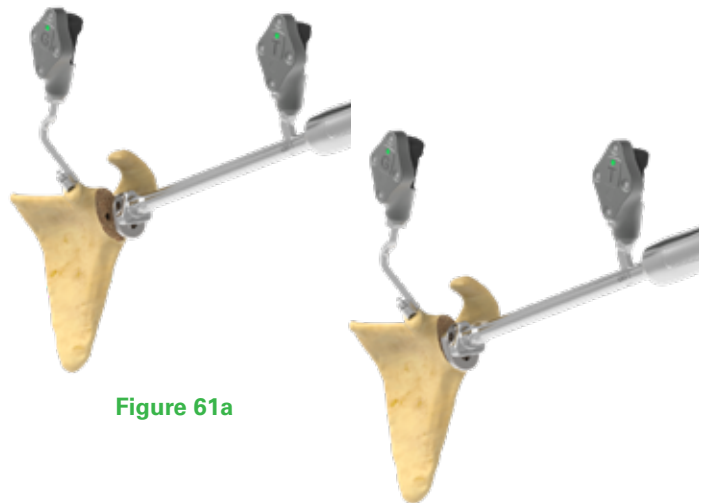

Figure 61a

Figure 61b

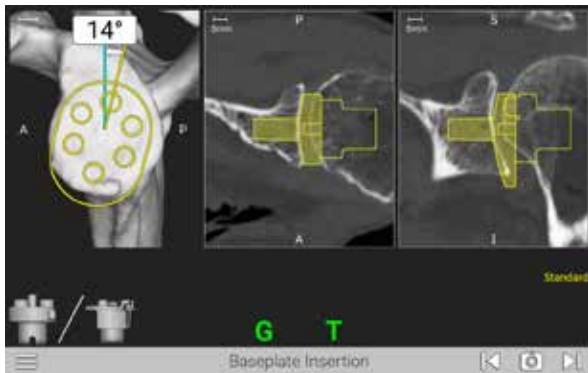

Figure 62a

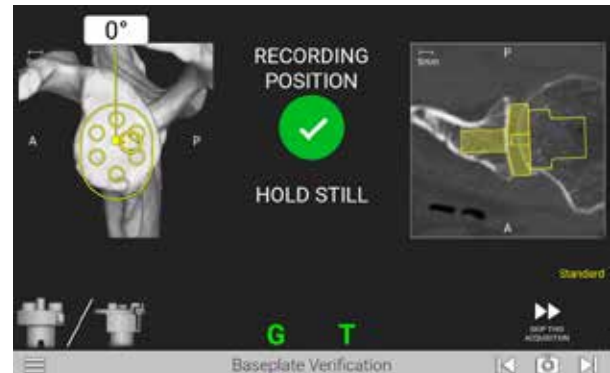

Figure 62b

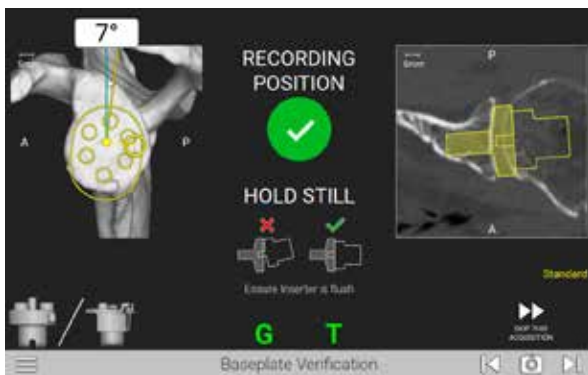

Figure 63

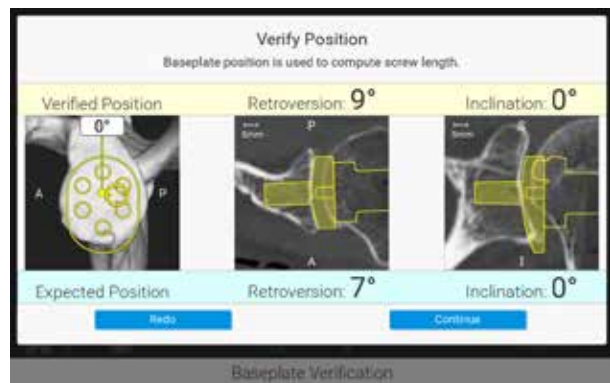

Figure 64

STEP 4A: IMPLANT INSERTION

GPS IMPACTOR HANDLE

Attach the appropriate corresponding reverse baseplate Impactor Tip to the **GPS Impactor Handle (531-07-05)** (Figure 60). Attach the T-Tracker to the Handle (ensuring left for left, right for right). Finally, place the planned baseplate onto the tip of the Baseplate Inserter (Figures 61a and 61b).

Note: It is helpful to utilize a “tug test” both rotationally and vertically to ensure the tracker is properly fixated on the instrument and to ensure it does not move.

Note: Ensure the superior portion of the implant is always oriented in the same direction as the Tracker.

WARNING: Don't assemble or disassemble devices in the surgical field.

Align the blue and yellow dots as done previously, while referencing the angular measurements, to impact the implant

based on the plan. The blue line represents the planned angle of the implant's rotation and will always be facing vertically. Because of this, the surgeon might notice that the scapula is rotated on this step (Figure 62a). Once the baseplate inserter is flush against the implant after being impacted, you may advance to the next screen, but do not remove the Impactor Handle and Baseplate Inserter Tip from the baseplate.

VERIFY POSITION

After implanting, hold the Impactor Handle and Inserter still and flush against the implant face. Press the Next button on the screen to capture the position of the implant placement, which will adjust the original plan to where the surgeon placed the implant (Figure 62b). Ensure the impactor handle is seated flush to the face of the baseplate while verifying its position (Figure 63). A pop-up will appear showing the verified position of the drill vs. the planned position. If the surgeon would like to re-do the digitization, press Re-do. If the surgeon accepts the digitization, press Continue (Figure 64).

After removing the T-Tracker from the GPS Impactor Handle, carefully place it on the GPS Driver.

DETAILED OPERATIVE TECHNIQUE

LEGACY REVERSE SHOULDER

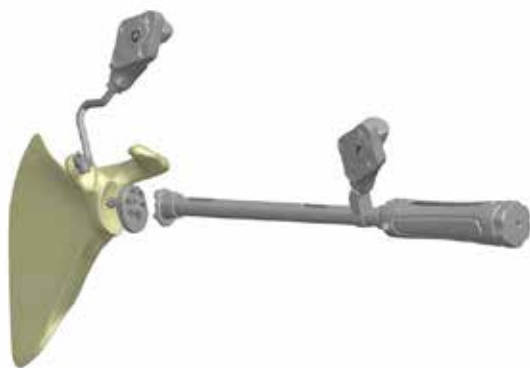

Figure 65a

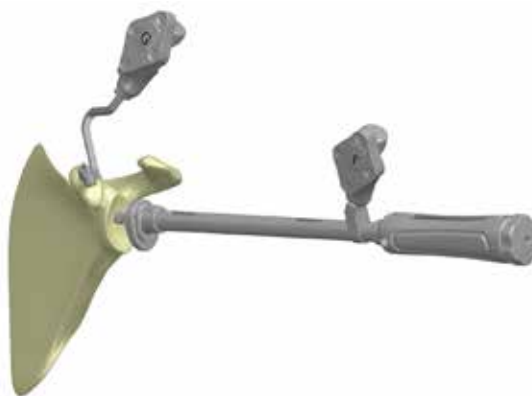

Figure 65b

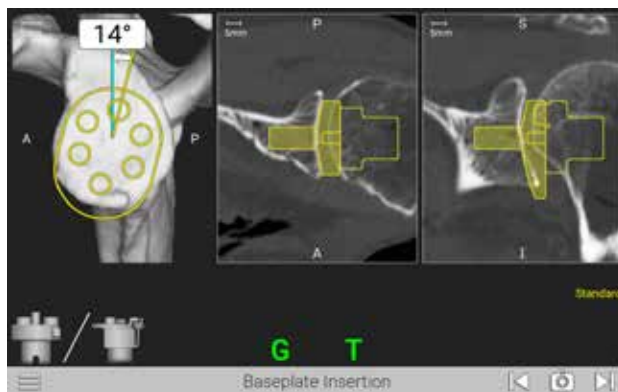

Figure 66

STEP 4B: IMPLANT INSERTION

GPS REVERSE INSERTER HANDLE

Attach the T-Tracker to the **GPS Reverse Inserter Handle (531-07-07)** (ensure left for left, right for right). Place the planned baseplate onto the tip of the Reverse Inserter Handle and use the knob at the top of the Reverse Inserter Handle to fasten it to the planned baseplate (Figures 65a and 65b).

Align the blue and yellow dots as done previously, while referencing the angular measurements, to insert the implant based on the plan. The blue line represents the angle of the implant's planned rotation and will always be facing vertically. Because of this, the surgeon might notice that the scapula is rotated on this step (Figure 66).

Once the planned Baseplate is fully seated on the Glenoid after impaction, you may advance to the next screen, but do not remove the GPS Reverse Inserter Handle from the baseplate.

Note: While detaching the baseplate with the knob feature, make sure to support the handle with other hand to maintain the inserter orientation.

Note: It is helpful to utilize a "tug test" both rotationally and vertically to ensure the tracker is properly fixated on the instrument and to ensure it does not move.

Note: The Reverse Inserter Handle is compatible with both Standard Baseplate and Small Baseplate.

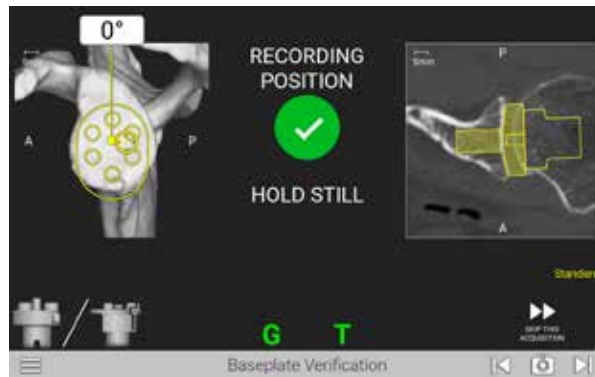

Figure 67

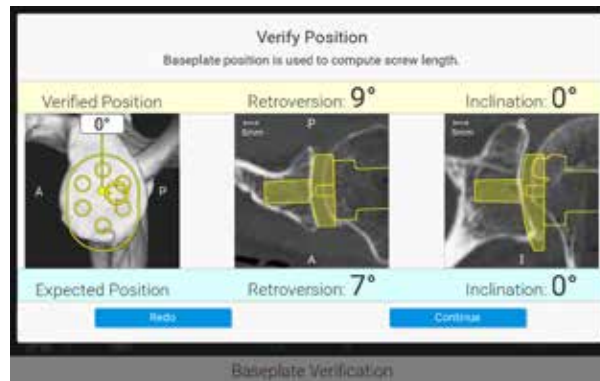

Figure 68

VERIFY POSITION

After implanting, hold the GPS Reverse Inserter Handle still and flush against the implant face. Press the Next button on the screen to capture the position of the implant placement, which will adjust the original plan to where the surgeon placed the implant (Figure 67).

A pop-up will appear showing the verified position of the drill vs. the planned position. If the surgeon would like to re-do the digitization, press Re-do. If the surgeon accepts the digitization, press Continue (Figure 68).

Using the knob at the top of the Reverse Inserter Handle, make sure to turn it counter-clockwise to unscrew it from the impacted baseplate.

Note: Always ensure the Inserter Handle is adequately supported after baseplate insertion until it's disconnected from the baseplate.

Note: For small baseplates, slide implant over the rTSA Handle's peg features, then pre-load the top peg's flexure while rotating the handle's knob.

DETAILED OPERATIVE TECHNIQUE

LEGACY REVERSE SHOULDER

LEGACY REVERSE SHOULDER



Figure 69

STEP 5: COMPRESSION SCREW NAVIGATION

Attach the **3.2mm GPS Drill (included in the sterile packed KIT 531-20-00)** to the GPS Driver (Figure 69). The 3.2 GPS Drill is sterile packed specifically for use with GPS. If not done already, re-attach the T-Tracker onto the GPS Driver.

Note: It is helpful to utilize a “tug test” both rotationally and vertically to ensure the Tracker is properly fixated on the instrument and to ensure it does not move.

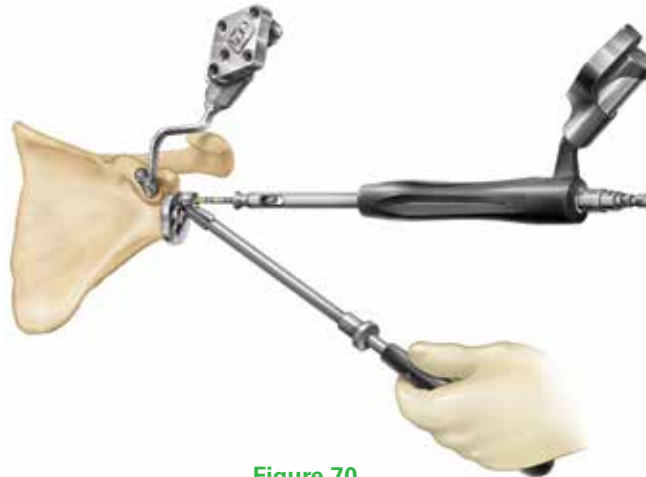

Figure 70

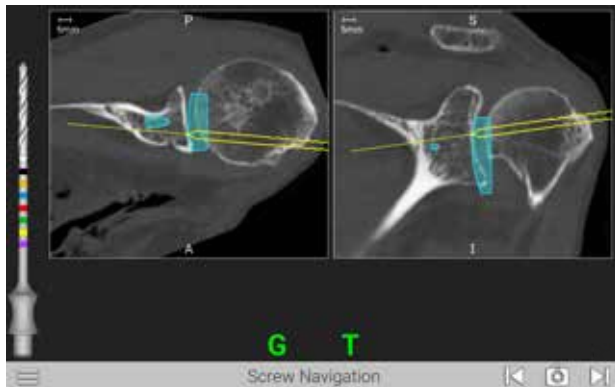

Figure 71a

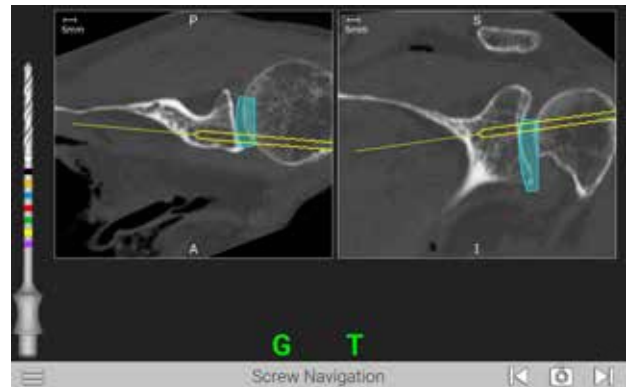

Figure 71b

Place the **Drill Guide** into the preferred hole of the Glenoid Plate and insert the Drill through the Guide (Figure 70).

Note: The baseplate holes and guide tip should be cleared of debris before screwing holes, as this can affect the depth indication (on the screen and on the drills).

The screen will display the trajectory of the Drill to allow for aiming for bicortical fixation, for example (Figures 71a and 71b). If the implant placement has successfully digitized, information related to the screw length will appear on the screen, along with active screw hole location.

Drill the **GPS 3.2mm Drill** through the **Drill Guide** and Baseplate hole. Once finished drilling the holes, be sure to disconnect the 3.2mm Drill from the Driver and remove it from the Drill Guide.

Note: Ensure the drill depth indicator reaches the base of the numeric engraving for the respective screw length.

Note: Since the GPS Driver uses a snap fit connection, the surgeon must drill in reverse upon removal of the drill bit from the bone.

Once the GPS technique is complete, remove the G Tracker and Coracoid Block before Glensphere insertion.



Complete remaining surgical steps per Equinox surgical technique (OPTECH-000204). At the end of the case, the sales representative will run GetStationLog on the GPS system to upload the case to the passkey. Make sure to upload all the cases to AI One.

LEGACY INSTRUMENT LISTING







CATALOG NUMBER	PART DESCRIPTION	
KIT-501, KIT501C or KIT-501+ GPS Station V2+ or V2C		
I00025 or I00020	Main GPS Unit	
I00021	Power Supply	
J00010	Lower Mounting Arm	
J00012, J00020 or J00065	Upper Mounting Arm	
J00011	GPS Bedrail Clamp	
I00022	GPS Travel Case	
KIT-501V3 GPS Station V3		
I00030	Main GPS Unit	
I00031	Power Supply	
J00010	Lower Mounting Arm	
J00065	Upper Mounting Arm	
J00011	GPS Bedrail Clamp	
I00032	GPS Travel Case	
KIT-501T GPS Trackers		
A10003	GPS Probe	
A00203	GPS Probe V2	
A10005	GPS T-Tracker	
A00205	GPS T-Tracker V2	
A10006	GPS G-Tracker	
A00206	GPS G-Tracker V2	
<i>Note: F Tracker currently used for knee and ankle cases only</i>		
KIT-531 GPS Shoulder Mechanical Instruments		
531-07-05	Impactor Handle	
531-07-07	GPS Reverse Inserter Handle	
531-01-03	Coracoid Block Left	
531-01-04	Coracoid Block Right	
531-25-00	GPS Driver	
531-27-60	Center Drill Bit	

CATALOG NUMBER PART DESCRIPTION



KIT-531 GPS Shoulder Legacy Mechanical Instruments

531-27-63	Cannulated Center Drill Bit	
301-09-80	Zimmer-Hudson Ratchet Handle	
521-78-11	Pin Driver, Short Low Profile	

KIT-531A GPS Shoulder Anatomic Instruments

531-27-04	Peripheral Peg Drill Guide, Left	
531-27-05	Peripheral Peg Drill Guide, Right	
531-27-14	8 Degree Posterior Augment Peripheral Peg Drill Guide, Left	
531-27-15	8 Degree Posterior Augment Peripheral Peg Drill Guide, Right	
531-29-14	16 Degree Posterior Augment Peripheral Peg Drill Guide, Left	
531-29-15	16 Degree Posterior Augment Peripheral Peg Drill Guide, Right	
531-07-50	Zimmer-Hudson Adapter	

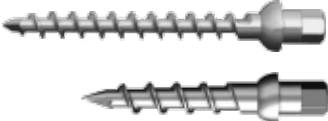
GPS Shoulder Disposables

531-78-20	Disposable Hex Pins Kit	
531-20-00	Disposable Reverse Drill Kit (2.0, 3.2mm drill bits)	

A10012 GPS V2+ or V2C Disposable Kit
 A10032 GPS V3 Disposable Kit
Includes sterile drape, batteries and cleaning wipe





Figure 72

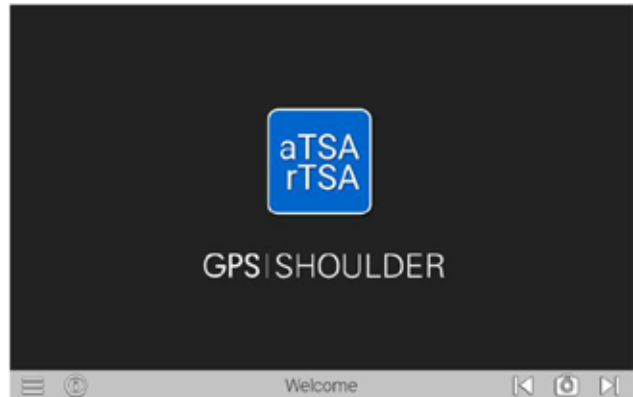

Figure 73

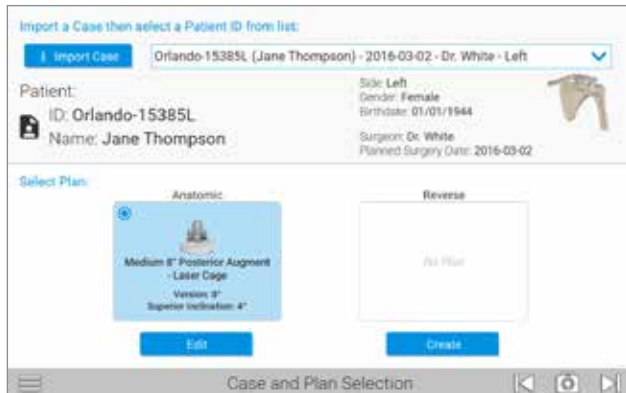

Figure 74



Figure 75

CASE AND PLAN SELECTION

Press the Shoulder Application icon on the GPS unit. If using a USB to transfer a case, on the Case and Plan Selection screen (Figure 74), select Import Case to import a case. If the case is already on the unit, click the box with the drop down and be sure to select the correct Patient ID. If using the AUGI App to transfer a case, once it is transferred, then click on the drop down menu and be sure to select the correct patient ID. Depending on what plans were exported, select the Anatomic or Reverse plans to navigate with GPS. Ensure the patient information displayed matches the patient in the OR.

Note: A plan can still be edited or created based on what was imported by pressing the Edit or Create button under the Anatomic or Reverse sections.

INSTRUMENTATION SELECTION

Next, on the instrumentation selection screen, verify the instrument set being used. If using Equinox Legacy GPS instruments, select the “change to Legacy button” at the top right of the screen and follow the 3.0 Equinox Legacy operative technique (Figure 75).

Next, select the option for either Pilot Tip or Cannulated instrumentation. Surgeons may also select/unselect whether they will be using the rotation and implant impaction/insertion instruments and features.

Verify that the correct orientation of the station setup by reviewing the Station Setup screen after advancing.

DETAILED OPERATIVE TECHNIQUE

ERGO ANATOMIC SHOULDER



Figure 76

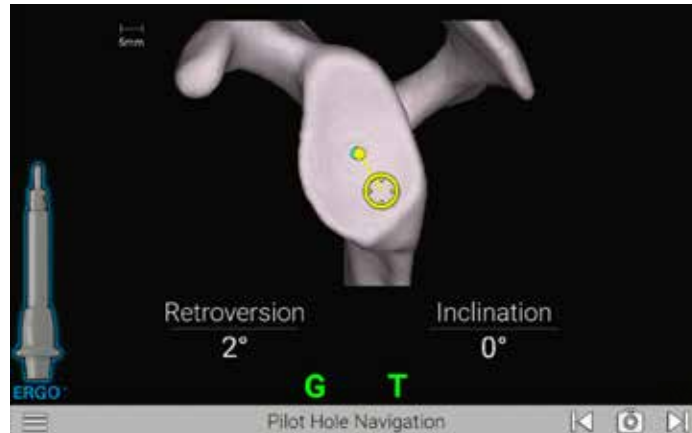

Figure 77



STEP 1: PILOT TIP DRILL

If not already done, carefully attach the **T-Tracker** to the **Pilot-tip Driver (531-55-00)**. Ensure the tracker is fixated on the tracker post with the tracker face aiming in the direction of the pilot tip of the driver.

Note: It is helpful to utilize a “tug test” both rotationally and vertically to ensure the tracker is properly fixated on the instrument and to ensure it does not move.

Use the Pilot-tip Driver to drill the glenoid pilot hole (Figure 76).

Follow the on-screen guidance to orient the GPS Ergo Driver according to the plan. Both the pilot hole and K-Wire insertion screens are guided in a similar fashion with real-time feedback on the position of the Driver and K-Wire Guide (Figure 77).

-  For positioning of the drill, the tip of the drill is indicated by a yellow dot.
-  The planned position is indicated by a blue dot.

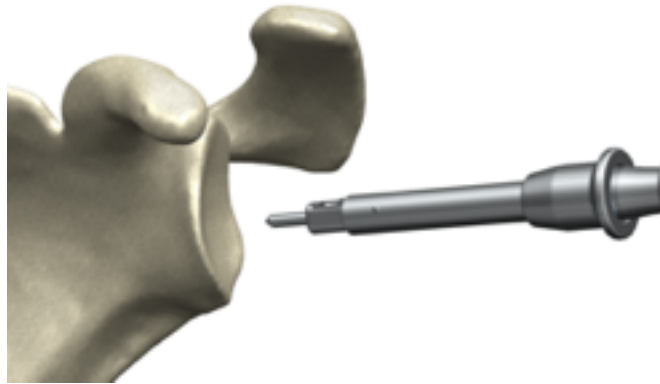

Figure 78

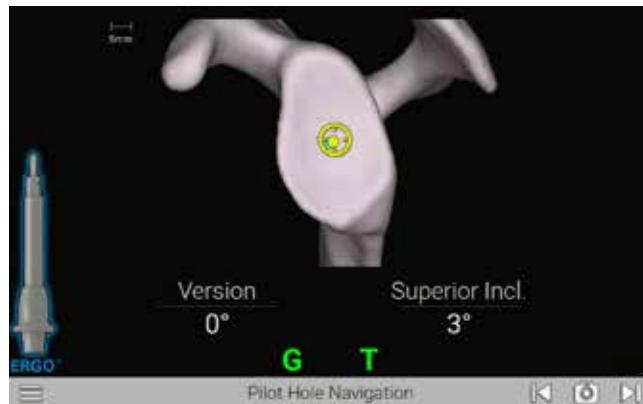

Figure 79

The orientation is guided by the circular cross-hair indicator. When the target is perfectly aligned, the screen will display the cross-hair superimposed on the yellow dot (Figure 79).

The surgeon may deviate from this plan if desired. This screen includes an image of the orientation that is synchronized with the CT scan slices to visualize the cortices. Follow the on-screen guidance to drill the center hole.

Press the Next arrow to proceed.

Note: At any point in the procedure, the surgeon may use the probe to advance to the next screen by pressing the forward button twice while facing the camera.

Note: Avoid applying a bending force to the GPS Driver or using the GPS Driver to retract the humeral head as this may cause fracture of the pilot tip feature.

Note: The numbers shown for version and inclination are displayed according to the preoperative plan.

WARNING: Don't assemble or disassemble devices in the surgical field.

DETAILED OPERATIVE TECHNIQUE

ERGO ANATOMIC SHOULDER

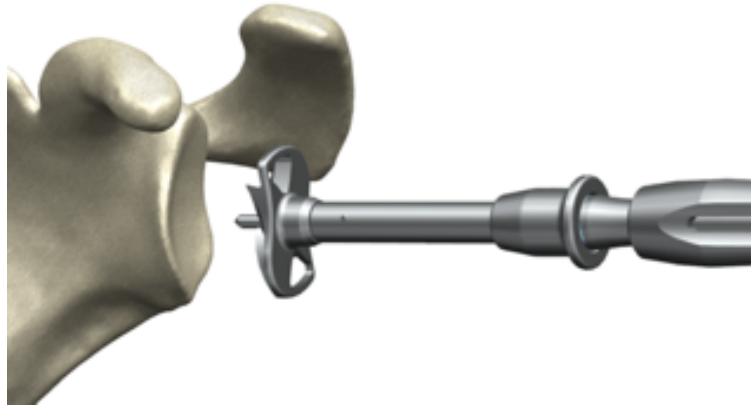

Figure 80

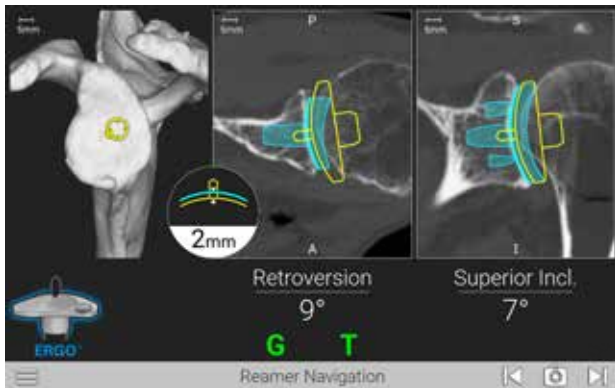

Figure 81a

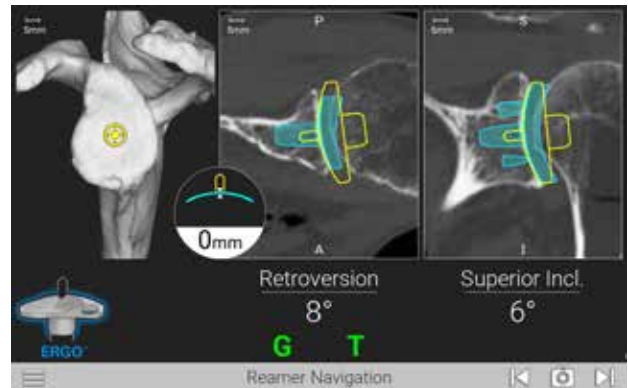

Figure 81b

STEP 2: GLENOID REAMING

Select an Anatomic Reamer per the Equinox Ergo surgical technique (OPTECH-000204) and attach it to the **Pilot-tip Driver** (Figure 80).

Follow the on-screen guidance to ream according to the plan (Figures 81a and 81b). The reaming screen is guided in a similar fashion to the pilot-hole guidance, with real-time feedback on the position of the pilot-tip and reamer curvature relative to the planned depth.

Press the Next arrow to proceed and detach the reamer.

Note: When preparing for augmented glenoid components, be aware that the drilling axis is different from the reaming axis. The system accounts for this; the surgeon does not need to adjust for this mismatch.

	Implant	Implant Length (mm)	Drill to Use	Drill Flute Length (mm)	Overdrill Amount (mm)
ANATOMIC	Cage Glenoid	14.5	STD	19.3	4.8
	Cage Glenoid - 8° Augment	15.9	STD	19.3	3.4
	Laser Cage Glenoid	14.6	STD	19.3	4.7
	Laser Cage Glenoid - 8 degree Augment	15.9	STD	19.3	3.4
	Pegged Glenoid - Standard	11.7	STD	19.3	7.6
	Pegged Glenoid - 8° Posterior Augment	11.6	STD	19.3	7.7
	Pegged Glenoid - 16° Posterior Augment	12.2	STD	19.3	7.1
	Keeled	16	STD	19.3	3.3

Note: Not all instruments and implants are available in every market.

Note: GPS Ergo Center Drills are coated to indicate size, reflected in the cell color. These color indications are also present on the relevant GPS screens. The standard GPS Ergo Drill is gold coated.

Table 1

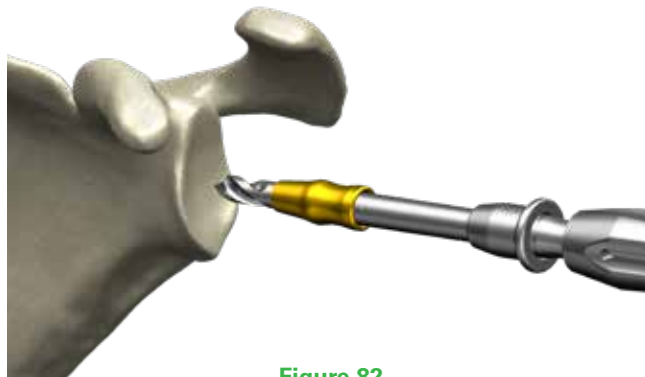

Figure 82

STEP 3: CENTER HOLE

Attach the corresponding GPS Ergo Center Drill to the Pilot-tip Driver (Figure 82).

Be sure to use the correct drill for the appropriate implant by referencing the bottom-left portion of the GPS screen, which highlights the correct drill (531-55-64).

DETAILED OPERATIVE TECHNIQUE

ERGO ANATOMIC SHOULDER

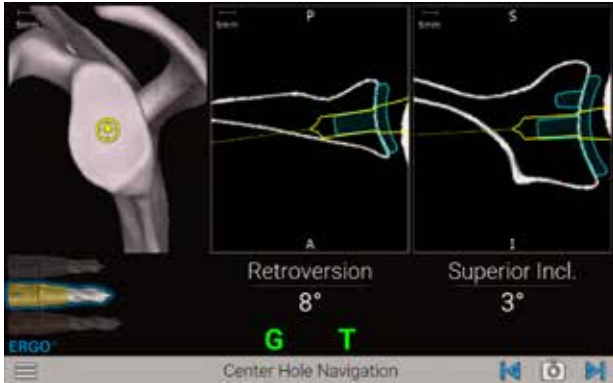

Figure 83a

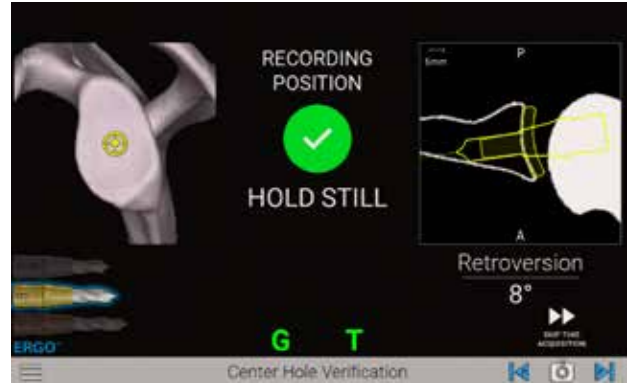

Figure 83b

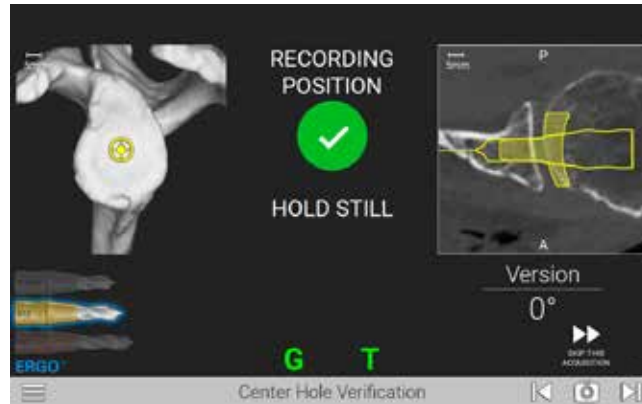

Figure 84

DRILLING

Drill the center cage hole for the Anatomic Glenoid Implant using the on-screen guidance with the cross-hairs, as used in the previous steps. Once the drill is fully seated, the surgeon may advance to the next screen **but do not take the drill out of the bone** (Figure 83a).

VERIFY POSITION

With the drill still fully seated in the bone, hold the Pilot-tip Driver in-place over the drilled axis to capture the position of the planned implant. The system will adjust the original plan to where the drill was actually placed. The system will advance to the next step automatically, accurately recording the drill axis location and orientation (Figure 83b).

A pop-up will appear showing the verified position of the drill vs. the planned position. If the surgeon would like to re-do the digitization, press Re-do. If the surgeon accepts the digitization, press Continue (Figure 84).



Figure 85



Figure 86

STEP 4: PERIPHERAL PEG DRILL GUIDANCE

PERIPHERAL PEG DRILL

Remove the T-Tracker from the Pilot-tip Driver and attach it to the **Zimmer-Hudson Adapter (301-09-80)**. Ensure Tracker LEDs are facing the direction of the indicated shoulder with the laser marking on the post under the Tracker (i.e. left for left, right for right).

Attach the male end of the Zimmer-Hudson Adapter to the Zimmer-Hudson handle, and the female end of the Zimmer-Hudson adapter to the appropriate Peripheral Peg Drill Guide for the planned anatomic glenoid implant, with the drill guide size marking reading right side up in the direction of the Tracker (Figure 85).

Ensure that the drill guide bottoms-out and fully engages with the Zimmer-Hudson adapter, and that the collar of the Zimmer-Hudson adapter fully deploys over the male end of the Zimmer-Hudson Drill Guide.

Next, from the **Standard Conventional Ergo Instrumentation**, attach the **Peripheral Peg Drill (315-52-62)** to the **Peripheral Peg Driver (315-52-01)** (Figure 86).

Note: It is helpful to utilize a “tug test” both rotationally and axially to ensure the tracker is properly fixated on the instrument and to ensure it does not move.

Note: If the plan includes an anterior augment, the Peripheral Drill Guide Peg Navigation step will NOT be included in the workflow.

DETAILED OPERATIVE TECHNIQUE

ERGO ANATOMIC SHOULDER

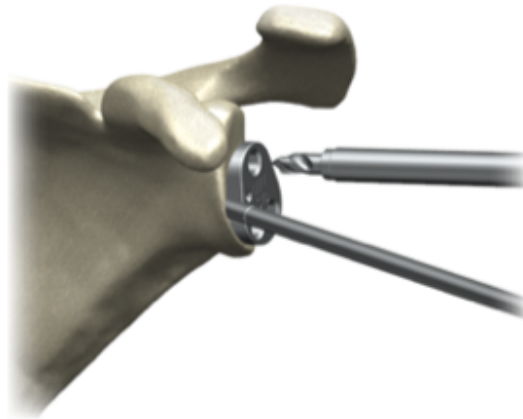

Figure 87

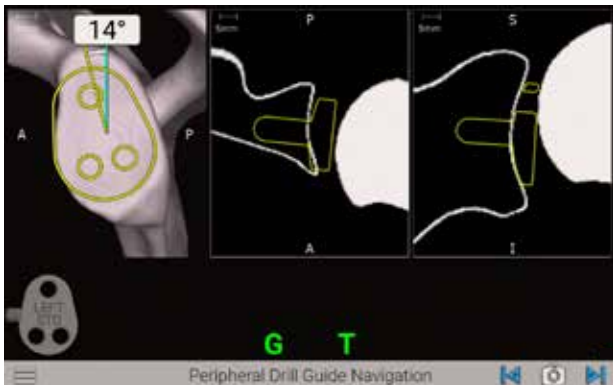

Figure 88a

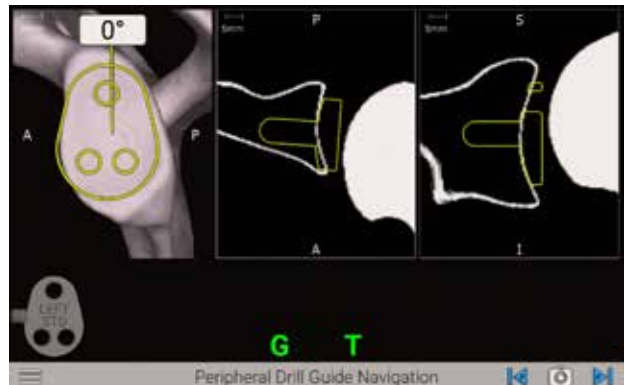

Figure 88b

Attach the Peripheral Peg Driver to a powered drill.

With one hand, hold the Peripheral Drill Guide and Zimmer-Hudson Adapter assembly with the T-Tracker attached.

With the other hand, insert the Peripheral Peg Drill into the Peripheral Peg Drill Guide (*Figure 87*).

Use the angle measurement on the screen to adjust the Peripheral Peg Drill Guide to the plan. The surgeon will want to rotate the Peripheral Peg Drill Guide to match the yellow line with the blue line. The degrees shown on screen represent the variability of the angle to plan, **not the overall planned rotation of the implant** (*Figures 88a and 88b*).

Drill each of the 3 peripheral peg holes, then remove all drills with guide. When finished drilling peripheral peg holes, remove the tools and advance the screen.



Figure 89a

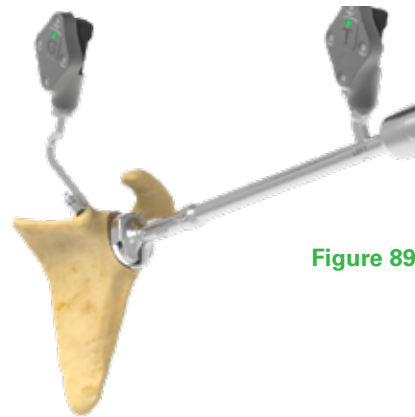

Figure 89b

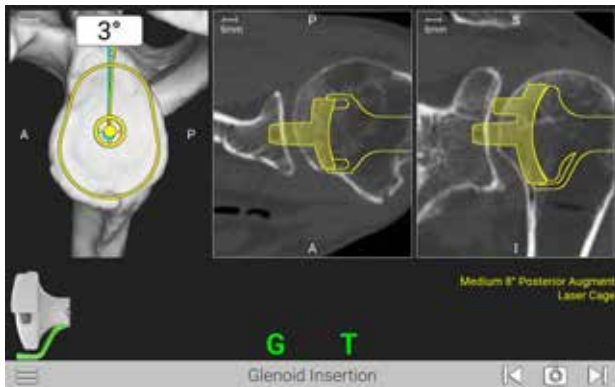

Figure 90a

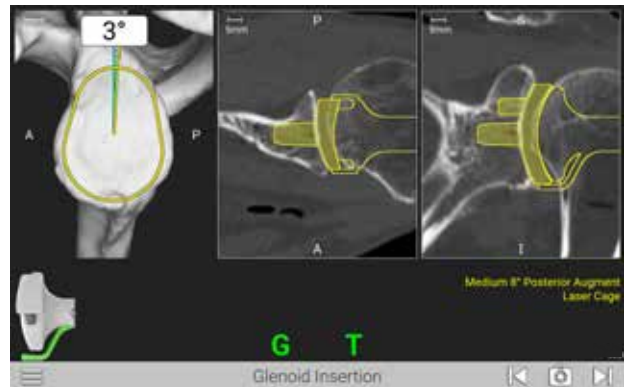

Figure 90b

STEP 5: IMPLANT INSERTION

IMPLANT INSERTION

Attach the appropriate anatomic Glenoid Inserter Impactor Tip to the GPS Impactor Handle (**531-07-05**). After removing the T-Tracker from the Zimmer-Hudson adapter from the prior step, place it onto the GPS Impactor Handle, again ensuring left for left, right for right (Figure 90).

Only Equinox Ergo Impactor Tips are compatible (315-54-02/03/04/05 and 315-55-02/03/04/05).

Use the onscreen prompts to place and impact the implant according to the plan. The screen will indicate the implant being impacted and it will show the corresponding color inserter to use for that specific implant.

Again, the degrees shown on screen represent the variability of the angle to plan, not the overall planned rotation of the implant. Once implant is fully seated, **do not remove the impactor and inserter.**

Note: It is helpful to utilize a “tug test” both rotationally and vertically to ensure the tracker is properly fixated on the instrument and to ensure it does not move.

Note: Ensure the superior portion of the implant is always oriented in the same direction as the Tracker (Figure 89).

WARNING: Don’t assemble or disassemble devices in the surgical field.

DETAILED OPERATIVE TECHNIQUE

ERGO ANATOMIC SHOULDER

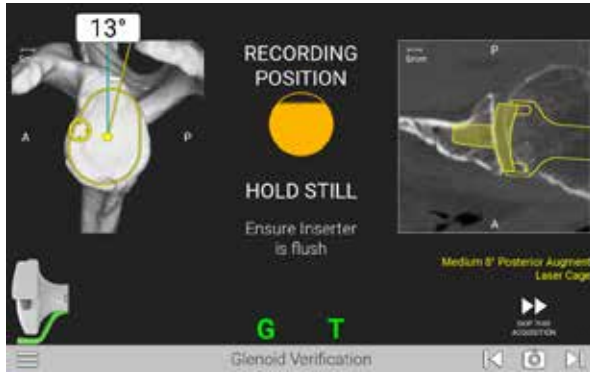

Figure 91a

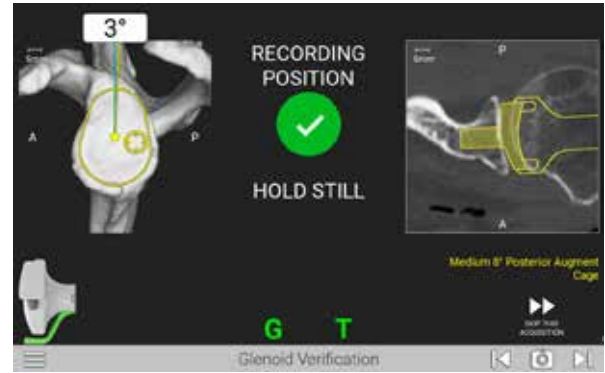

Figure 91b

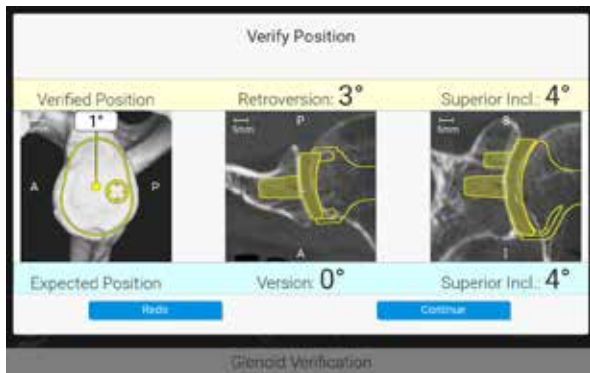

Figure 92

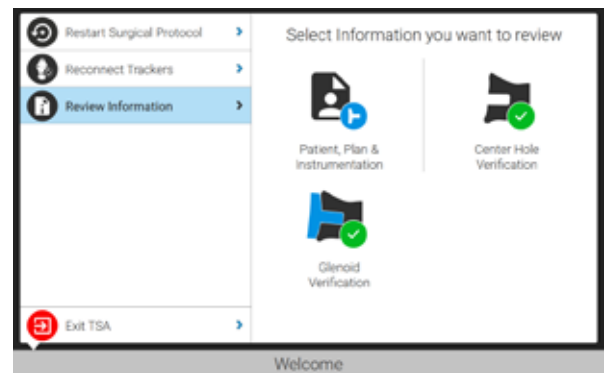

Figure 93

VERIFY POSITION

After implanting, hold the Impactor Handle and ensure the Inserter is still and flush against the implant face (Figure 91a). Press the Next button on the screen to capture the position of the implant placement (Figure 91b).

A pop-up will appear showing the verified position of the implant vs. the planned position. If the surgeon would like to redo the digitization, press Re-do (Figure 92). If the surgeon accepts the digitization, press Continue to capture the verified implant placement. Once the navigated part of the procedure is complete, remove the G Tracker and Coracoid Block.

Complete remaining surgical steps per Equinox Ergo surgical technique. At the end of the case, the sales representative will run GetStationLog on the GPS system to upload the case. Make sure to upload all cases to AI One. Case reports showing the final verified implant placement are available on the surgeon's AI One account.

Note: You can always review the plan by pressing the menu button and selecting "Review Information" from the pop-up menu on the left (Figure 93).

ERGO REVERSE SHOULDER

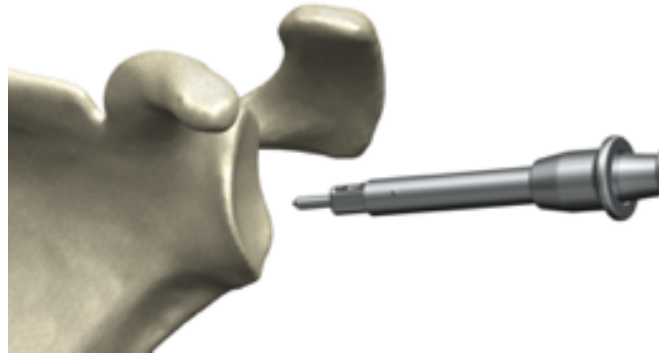

Figure 94a

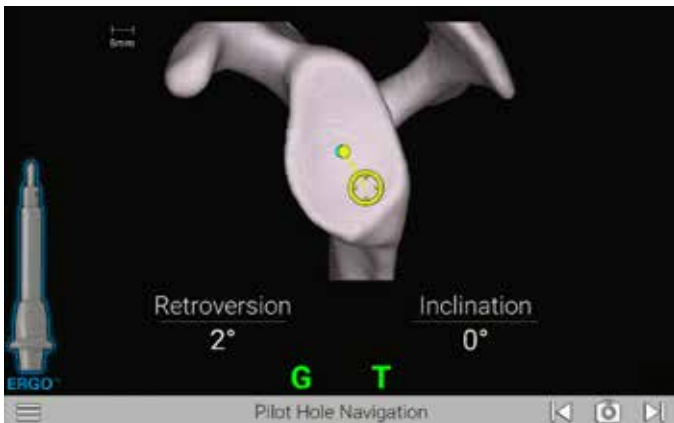

Figure 94b

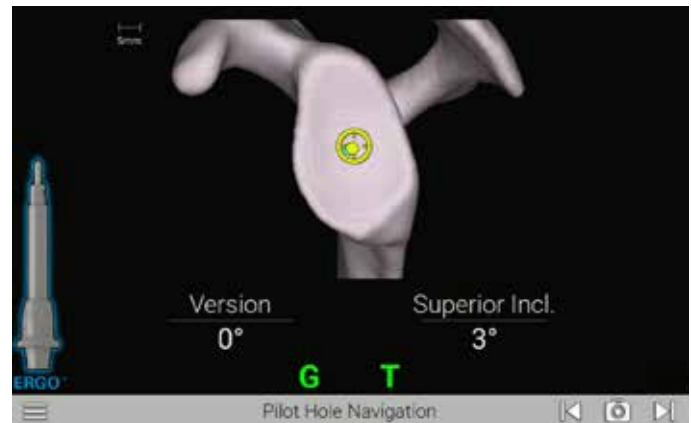

Figure 94c

STEP 1: PILOT TIP DRILL

Attach the **T-Tracker** to the **Pilot-tip Driver (531-55-00)**.

Use the Pilot-tip Driver to drill the glenoid pilot hole (Figure 94a).

Follow the on-screen guidance to place the components according to the plan (Figure 94b). Both the pilot hole and K-Wire insertion screens are guided in a similar fashion with real-time feedback on the position of the Driver and K-Wire Guide.

Press the Next arrow to proceed.

- For positioning of the Drill, the tip of the Drill is indicated by a yellow dot.
- The planned position is indicated by a blue dot.

The orientation is guided by the circular crosshair indicator. When the target is perfectly aligned, the screen will display the crosshair

superimposed on the yellow dot (Figure 94c). Follow the on-screen guidance to drill the center.

Note: Avoid applying a bending force to the GPS Driver or using the GPS Driver to retract the humeral head as this may cause fracture of the pilot tip feature.

Note: The numbers shown for version and inclination are displayed according to the preoperative plan.

Note: The plan may not necessarily read 0° version and 0° inclination. The surgeon may deviate from this plan if desired. This screen includes an image of the orientation that is synchronized with the CT scan slices to visualize the cortices.

WARNING: Don't assemble or disassemble devices in the surgical field.

DETAILED OPERATIVE TECHNIQUE

ERGO REVERSE SHOULDER

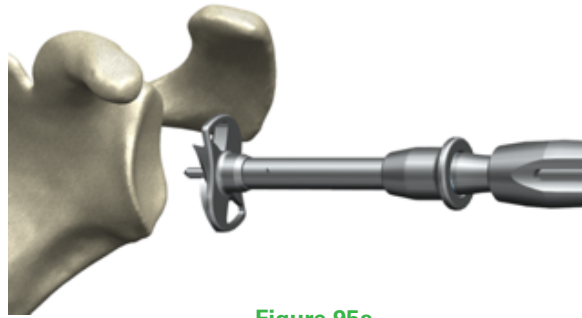

Figure 95a

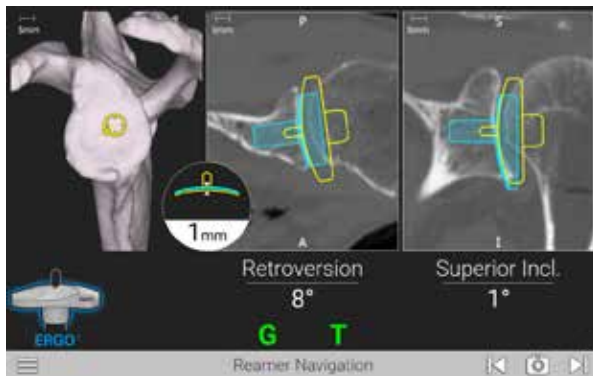

Figure 95b

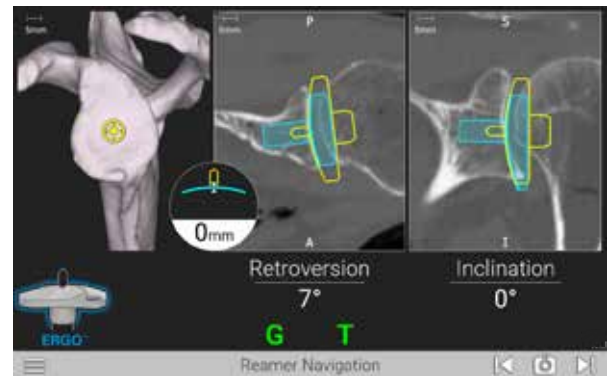

Figure 95c

STEP 2: GLENOID REAMING

Select a **Reverse Reamer** per the Equinox Ergo surgical technique (OPTECH-000204) and attach it to the **Pilot-tip Driver** (Figure 95a).

Follow the on-screen guidance to ream according to the plan (Figure 95b). The reaming screen is guided in a similar fashion to the pilot-hole guidance, with real-time feedback on the position of the pilot-tip and reamer curvature relative to the planned depth (Figure 95c).

Press the Next arrow to proceed and detach the reamer.

Note: When preparing for augmented glenoid components, be aware that the drilling axis is different from the reaming axis. The system accounts for this; the surgeon does not need to adjust for this mismatch.

	Implant	Implant Length (mm)	Drill to Use	Drill Flute Length (mm)	Overdrill Amount (mm)
REVERSE	Glenoid Baseplate - Standard	16.8	STD	19.3	2.5
	Glenoid Baseplate - 10° Superior Augment	18.3	STD	19.3	1
	Glenoid Baseplate - 8° Posterior Augment	16.8	STD	19.3	2.5
	Glenoid Baseplate - 10mm Extended Cage	26.8	EXT	25.3	-1.5*
	Glenoid Baseplate - Superior Posterior Augment	23.3	EXT	25.3	2
SMALL REVERSE	Small Glenoid Baseplate - Standard	13.1	SHORT	15.6	2.5
	Small Glenoid Baseplate - 10° Superior Augment	14.3	SHORT	15.6	1.3
	Small Glenoid Baseplate - 8° Posterior Augment	13.9	SHORT	15.6	1.7
	Small Glenoid Baseplate - 10mm Extended Cage	23.1	EXT	25.3	2.2
	Small Glenoid Baseplate - Superior Posterior Augment	18	STD	19.3	1.3

- Extended Drill
- Standard Drill
- Short Drill

Note: Not all instruments and implants are available in every market.

*Drill into the native glenoid bone first, and then add the graft and drill into the graft, as the drill is short.

Note: GPS Ergo Center Drills are coated to indicate size, reflected in the cell color. These color indications are also present on the relevant GPS screens. The short GPS Ergo drill is left uncoated (silver), the standard GPS Ergo drill is gold coated, and the extended GPS Ergo drill is rose-gold coated.

Table 2

DETAILED OPERATIVE TECHNIQUE

ERGO REVERSE SHOULDER

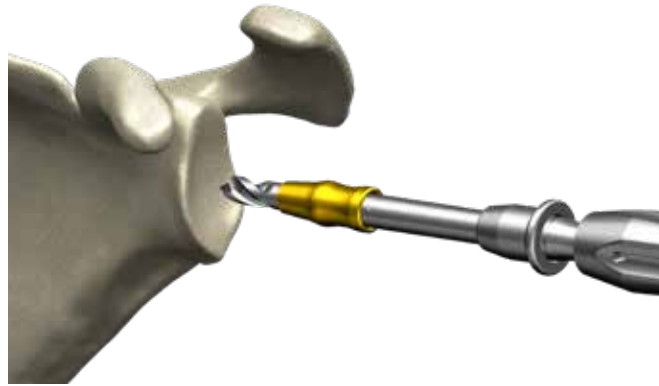

Figure 96a

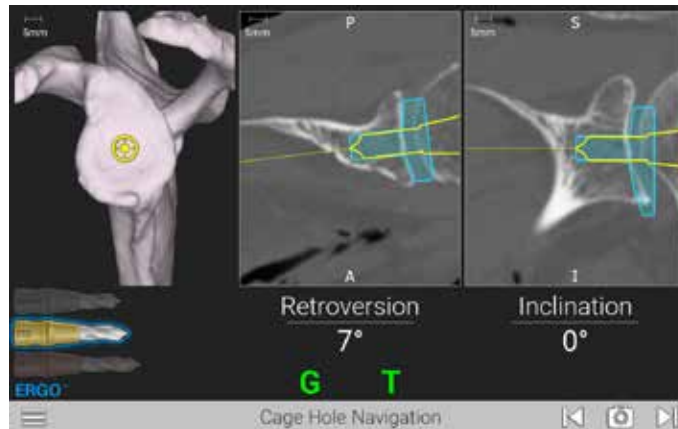

Figure 96b

STEP 3: CAGE DRILL GUIDANCE

Attach the corresponding **GPS Ergo Center Drill** to the **Pilot-tip Driver**. Be sure to use the correct drill based on the implant being used, refer to *Table 2* above. Refer to the indicated size on screen (*Figures 96a and 96b*).

DRILLING

Drill the center cage hole for the planned **Baseplate Implant** (*Figure 96b*).

Once the drill is fully seated, the surgeon may advance to the next screen, **but do not take the drill out of the bone**.

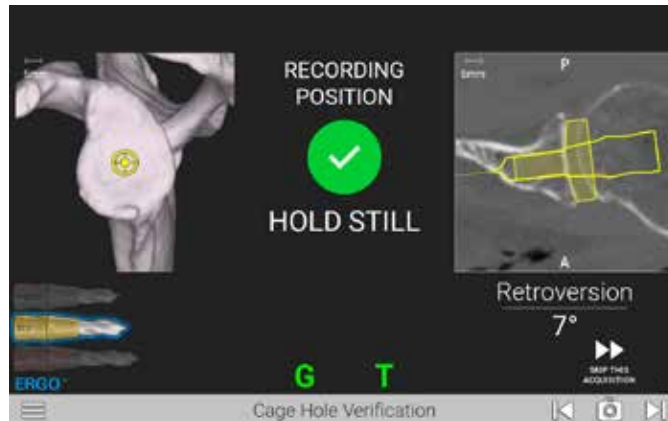

Figure 97

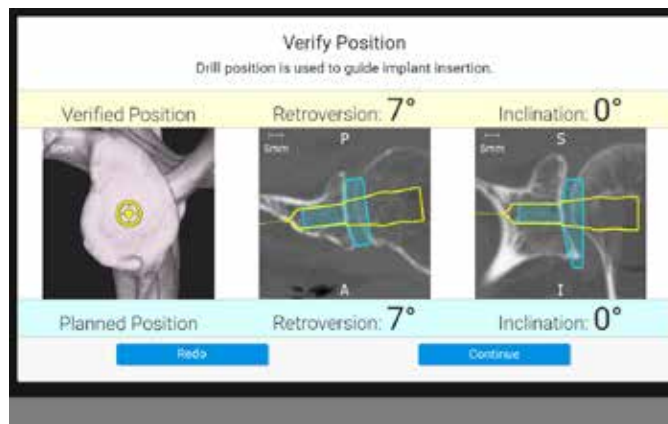

Figure 98

VERIFY POSITION

With the drill still fully seated in the bone, hold the Pilot-tip Driver in place over the drilled axis to capture the position of the planned implant (Figure 97). The system will adjust the original plan to where the drill was actually placed. The system will advance to the next screen automatically, accurately recording the drill axis location and orientation.

A pop-up will appear showing the verified position of the drill vs. the planned position (Figure 98). If the surgeon would like to re-do the digitization, press Re-do. If the surgeon accepts the digitization, press Continue.

After removing the T-tracker from the GPS Ergo Driver, carefully place it on the GPS Impactor Handle or GPS Reverse Inserter Handle.

Baseplate Inserter Chart

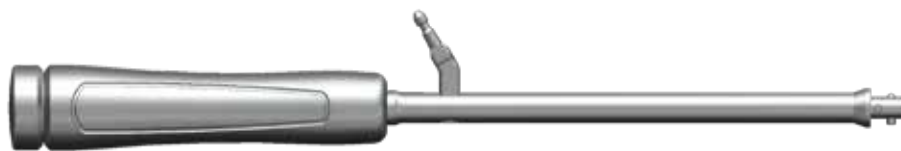

GPS Impactor Handle



GPS Reverse Inserter Handle

Figure 99

Figure 100

GPS Impactor Handle
Compatible Baseplate Inserters



321-19-13 — Ergo Inserter (Pilot)



321-19-14 — Ergo Inserter



321-35-23 and 321-35-24 —
Ergo Small Reverse Baseplate Inserter

Superior

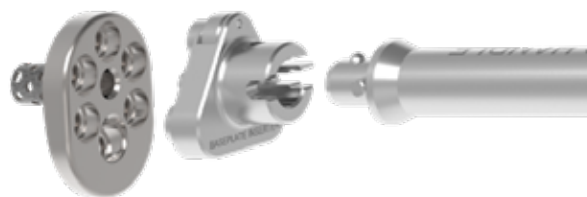

Inferior



Figure 101a

Figure 101b

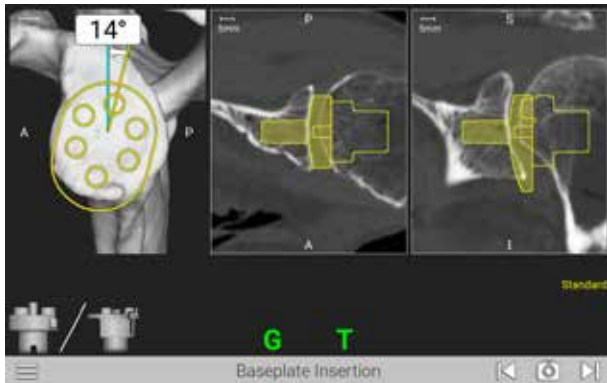

Figure 102a



Figure 102b

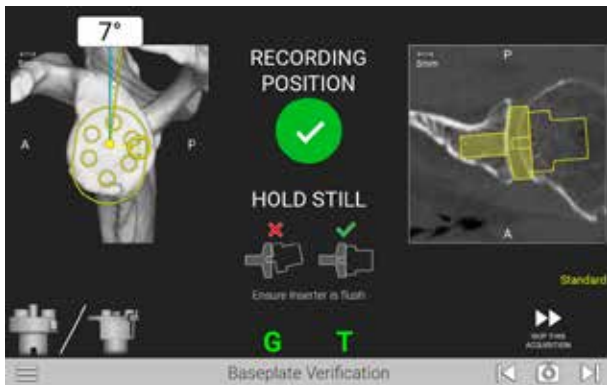

Figure 103

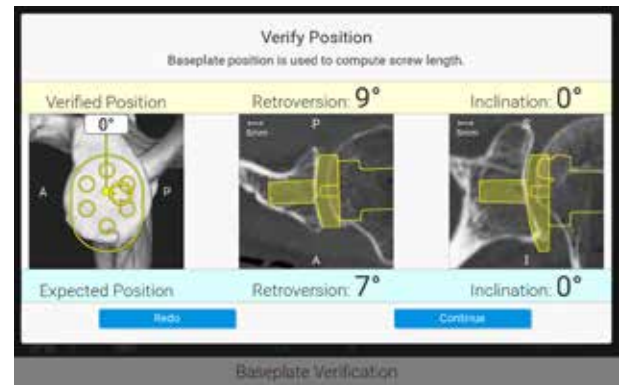

Figure 104

STEP 4A: IMPLANT INSERTION

GPS IMPACTOR HANDLE

Attach the appropriate corresponding reverse baseplate Impactor Tip to the **GPS Impactor Handle (531-07-05)** (Figure 100). Attach the T-Tracker to the Handle (ensuring left for left, right for right) (Figures 101a and 101b).

Note: Ensure the superior portion of the implant is always oriented in the same direction as the Tracker (Figures 99).

Note: It is helpful to utilize a “tug test” both rotationally and vertically to ensure the tracker is properly fixated on the instrument and to ensure it does not move.

WARNING: Don't assemble or disassemble devices in the surgical field.

The blue line represents the planned angle of the implant's rotation and will always be facing vertically (Figure 102a). Because of this, the surgeon might notice that the scapula is

rotated on this step. Align the blue and yellow dots as done previously, while referencing the angular measurements, to impact the implant based on the plan (Figure 102b).

VERIFY POSITION

After implanting, hold the Impactor Handle and Inserter still and flush against the implant face. Press the Next button on the screen to capture the position of the implant placement, which will adjust the original plan to where the surgeon placed the implant (Figure 102b). Ensure the impactor handle is seated flush to the face of the baseplate while verifying its position (Figure 103).

A pop-up will appear showing the verified position of the drill vs. the planned position. If the surgeon would like to re-do the digitization, press Re-do. If the surgeon accepts the digitization, press Continue (Figure 104).

After removing the T-tracker from the GPS Impactor Handle, carefully place it on the GPS Driver.

DETAILED OPERATIVE TECHNIQUE

ERGO REVERSE SHOULDER

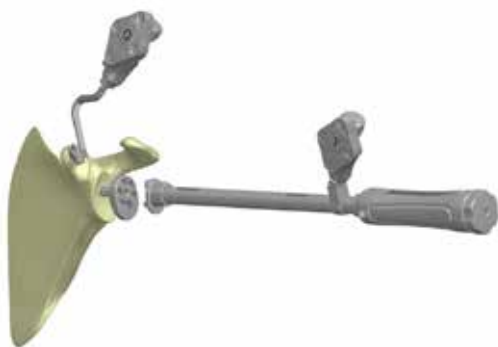

Figure 105a



Figure 105b

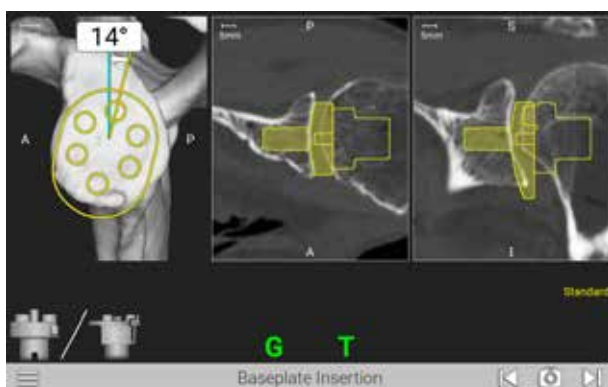

Figure 106

STEP 4B: IMPLANT INSERTION

GPS REVERSE INSERTER HANDLE

Attach the T-Tracker to the **GPS Reverse Inserter Handle (531-07-07)** (ensure left for left, right for right). Place the planned baseplate onto the tip of the Reverse Inserter Handle and use the knob at the top of the Reverse Inserter Handle to screw it in the planned baseplate (*Figures 105a and 105b*).

Align the blue and yellow dots as done previously, while referencing the angular measurements, to impact the implant based on the plan. The blue line represents the planned angle of the implant's rotation and will always be facing vertically. Because of this, the surgeon might notice that the scapula is rotated on this step. Once the planned Baseplate is fully seated on the Glenoid after impaction, you may advance to the next screen, but do not remove the GPS Reverse Inserter Handle from the baseplate (*Figure 106*).

Note: While detaching the baseplate with the knob feature, make sure to support the handle with other hand to maintain the inserter orientation.

Note: It is helpful to utilize a "tug test" both rotationally and vertically to ensure the tracker is properly fixated on the instrument and to ensure it does not move.

Note: The Reverse Inserter Handle is compatible with both Standard Baseplate and Small Baseplate.

Note: For small baseplates, slide implant over the rTSA Handle's peg features, then pre-load the top peg's flexure while rotating the handle's knob.



Figure 107

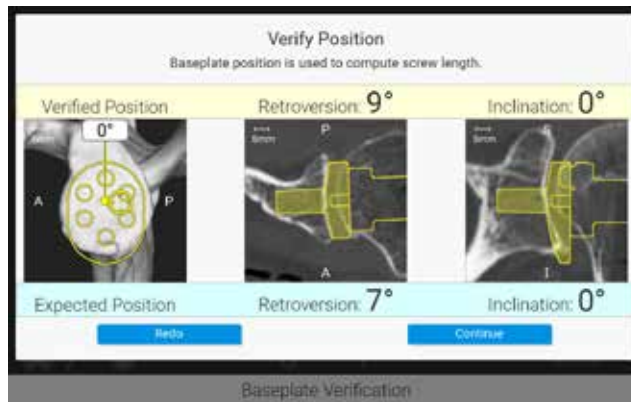

Figure 108

VERIFY POSITION

After implanting, hold the GPS Reverse Inserter Handle still and flush against the implant face. Press the Next button on the screen to capture the position of the implant placement, which will adjust the original plan to where the surgeon placed the implant (Figure 107).

A pop-up will appear showing the verified position of the drill vs. the planned position. If the surgeon would like to re-do the digitization, press Re-do. If the surgeon accepts the digitization, press Continue (Figure 108).

Using the knob at the top of the Reverse Inserter Handle, make sure to turn it counter-clockwise to unscrew it from the impacted.

Note: Always ensure the Inserter Handle is adequately supported after baseplate insertion until it's disconnected from the baseplate.

DETAILED OPERATIVE TECHNIQUE

ERGO REVERSE SHOULDER



Figure 109



Figure 110

STEP 5: COMPRESSION SCREW NAVIGATION

Attach the sterile packed **Ergo GPS 3.2mm Drill (531-55-88)** to the **GPS Driver**. The Ergo GPS 3.2mm Drill is sterile packed specifically for use with GPS. Note that the sterile-packed GPS Ergo Reverse drill bit does not have the colors indicated on the drill. Re-attach the T-Tracker onto the GPS Driver (Figure 109).

Next, clip the **GPS 3.2mm Drill Guide (531-55-09)** to the **Ergo GPS 3.2mm Drill (Figure 110)**. The surgeon can use the standard Ergo Drill Guide and confirm depth with **Ergo Depth Gauge (321-19-09)** or the new GPS 3.2mm Drill Guide when navigating the screw placement.

Note: The surgeon should drill in reverse upon removal of the drill bit from the bone.

Note: The baseplate holes and guide tip should be cleared of debris before screwing holes, as this can affect the depth indication (on the screen and on the drills).



Figure 111

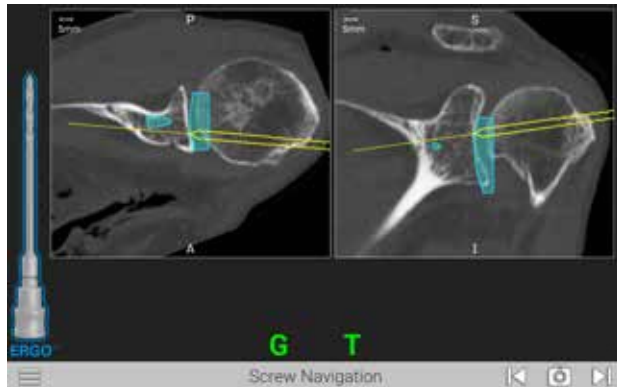

Figure 112a

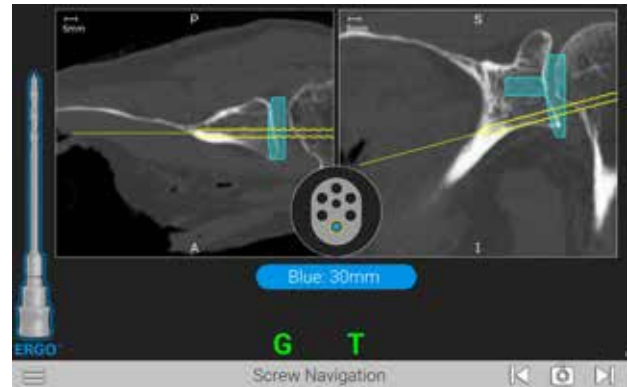

Figure 112b

Place the **GPS 3.2mm Drill Guide** tip into the preferred hole of the Glenoid Baseplate and prepare to drill the **3.2mm Drill** hole (Figure 111).

The screen will display the trajectory of the Drill to allow for aiming for bicortical fixation, for example (Figures 112a and 112b). If the implant placement has successfully digitized, information related to the screw length will appear on the screen, along with active screw hole location.

If not successfully digitized, information about screw length will NOT appear on the screen. Use the Ergo 3.2mm drill guide sleeve or a depth gauge to measure the screw length and location.

Drill the **Ergo GPS 3.2mm Drill** through the **3.2mm Guide** and Baseplate hole. Once finished drilling the holes, be sure to disconnect the 3.2mm Drill from the Driver and remove it from the Drill Guide.

Note: Ensure the drill depth indicator reaches the base of the numeric engraving for the respective screw length.

Once the GPS technique is complete, remove the GTracker and Coracoid Block before Glenosphere insertion.

Complete remaining surgical steps per Equinox surgical technique (OPTECH-000204).

ERGO INSTRUMENT LISTING

CATALOG NUMBER	PART DESCRIPTION	
KIT-501, KIT501C or KIT-501+ GPS Station V2+ or V2C		
I00025 or I00020	Main GPS Unit	
I00021	Power Supply	
J00010	Lower Mounting Arm	
J00012, J00020 or J00065	Upper Mounting Arm	
J00011	GPS Bedrail Clamp	
I00022	GPS Travel Case	
KIT-501V3 GPS Station V3		
I00030	Main GPS Unit	
I00031	Power Supply	
J00010	Lower Mounting Arm	
J00065	Upper Mounting Arm	
J00011	GPS Bedrail Clamp	
I00032	GPS Travel Case	
KIT-501T GPS Trackers		
A10003	GPS Probe	
A00203	GPS Probe V2	
A10005	GPS T-Tracker	
A00205	GPS T-Tracker V2	
A10006	GPS G-Tracker	
A00206	GPS G-Tracker V2	
<i>Note: F Tracker currently used for knee and ankle cases only</i>		
KIT-531Ergo GPS Shoulder Ergo Mechanical Instruments		
531-07-05	Impactor Handle	
531-07-07	GPS Inserter Handle	
531-01-03	Coracoid Block Left	
531-01-04	Coracoid Block Right	
531-55-00	Ergo GPS Pilot-tip Driver	

CATALOG NUMBER PART DESCRIPTION

531-55-09 Ergo GPS 3.2mm Drill Guide



531-55-62: Short (silver)
 531-55-64: STD (gold)
 531-55-66: EXT (rose gold) Ergo GPS Pilot-tip Center Drill Bits



521-78-11 Pin Driver, Short Low Profile



KIT-531A GPS Shoulder Ergo Anatomic Instruments

531-27-04 Peripheral Peg Drill Guide, Left



531-27-05 Peripheral Peg Drill Guide, Right



531-27-14 8 Degree Posterior Augment Peripheral Peg Drill Guide, Left



531-27-15 8 Degree Posterior Augment Peripheral Peg Drill Guide, Right



531-29-14 16 Degree Posterior Augment Peripheral Peg Drill Guide, Left



531-29-15 16 Degree Posterior Augment Peripheral Peg Drill Guide, Right



531-07-50 Shoulder GPS Hudson Adapter



ERGO INSTRUMENT LISTING

CATALOG NUMBER PART DESCRIPTION

GPS Shoulder Disposables

531-78-20 Disposable Hex Pins Kit



531-55-88 Ergo GPS Disposable Reverse Drill Kit



A10012 GPS V2+ or V2C Disposable Kit
 A10032 GPS V3 Disposable Kit
Includes sterile drape, batteries and cleaning wipe



DETAILED OPERATIVE TECHNIQUE

CANNULATED ANATOMIC SHOULDER



Figure 113

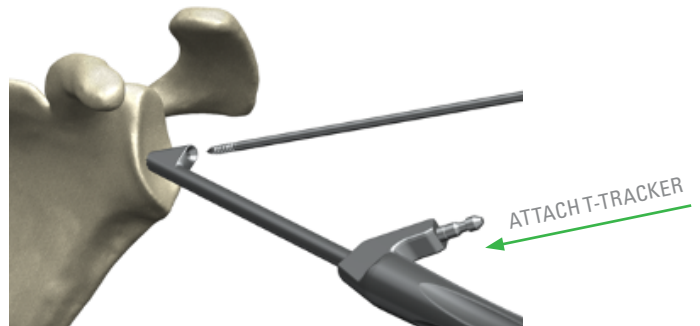

Figure 114

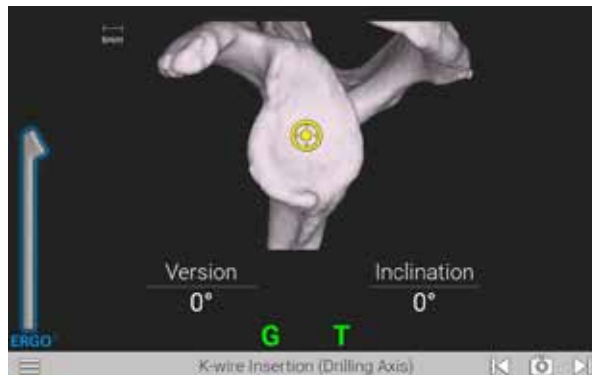



Figure 115

STEP 1: K-WIRE INSERTION FOR REAMING

At the beginning of the workflow, the surgeon can choose to do cannulated reaming only, or cannulated drilling and reaming (Figure 113).

For the cannulated workflow, attach the T-Tracker to the **GPS K-Wire Guide (531-55-26)** (Figure 114) and insert a **Ergo 3.2mm K-Wire (321-52-08/09/10)** to guide the placement of the wire.

Follow the on-screen guidance to place the components according to the plan.

 For positioning of the drill, the tip of the drill is indicated by a yellow dot.

 The planned position is indicated by a blue dot.

The orientation is guided by the circular cross-hair indicator. When the target is perfectly aligned, the screen will display the cross-hair superimposed on the yellow dot. The surgeon may deviate from this plan if desired. Press the Next arrow to proceed (Figure 115).

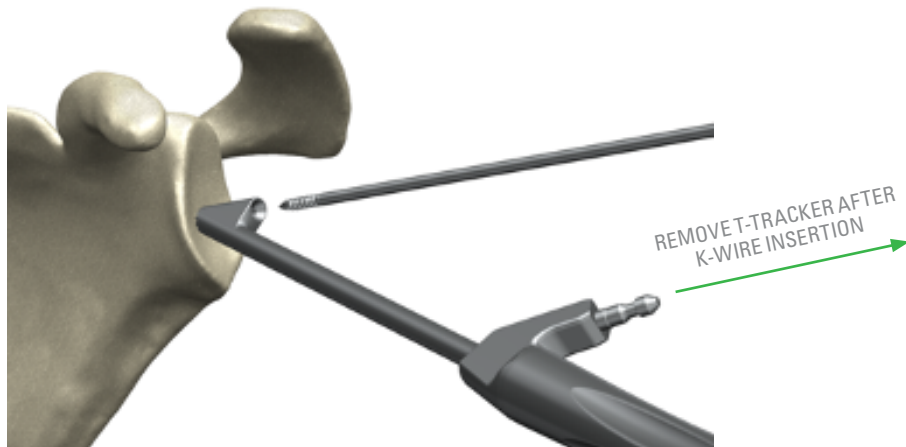

Figure 116

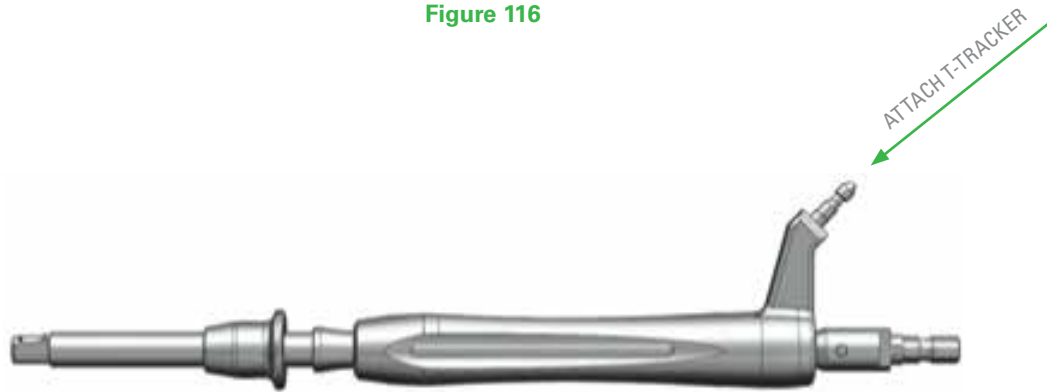

Figure 117

Note: If using a standard (non-augmented) glenoid, no options will show as there is no difference in the reaming and drill axis.

Note: It is helpful to utilize a “tug test” both rotationally and vertically to ensure the tracker is properly fixated on the instrument and to ensure it does not move.

Note: Avoid applying a bending force to the GPS Driver or using the GPS Driver to retract the humeral head as this may cause fracture of the 3.2mm K-Wire or pilot tip feature.

Note: The numbers shown for version and inclination are displayed according to the preoperative plan.

Once the K-Wire is fixed in the bone, remove the T-Tracker from the GPS K-Wire Guide (Figure 116) and attach to the **GPS Ergo Cannulated Driver (531-55-01)** (Figure 117).

Note: At any point in the procedure, the surgeon may use the probe to advance to the next screen by pressing the forward button twice while facing the camera.

DETAILED OPERATIVE TECHNIQUE

CANNULATED ANATOMIC SHOULDER

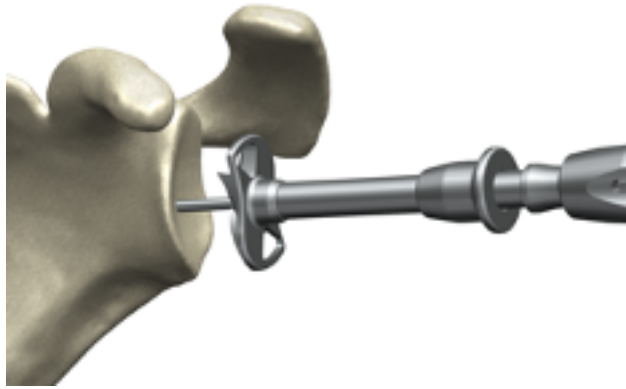

Figure 118

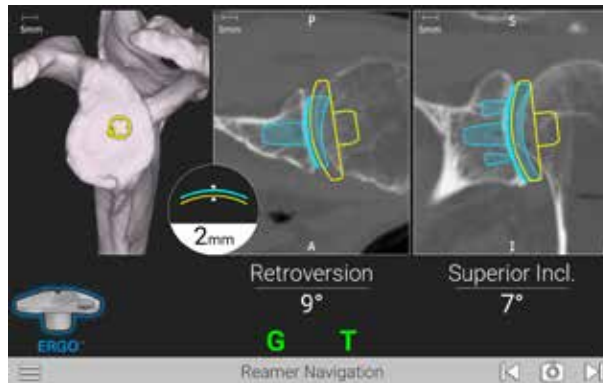

Figure 119

STEP 2: GLENOID REAMING

Select an **Anatomic Reamer** per the Equinox Ergo surgical technique (OPTECH-000204) and attach it to the **GPS Ergo Cannulated Driver** (Figure 118).

Follow the on-screen guidance to ream according to the plan. The reaming screen is guided in a similar fashion as the K-Wire Guide, with real-time feedback on the position of the reamer curvature relative to the planned depth (Figure 119).

If not using the K-Wire for the center hole, the K-Wire can be removed.

Press the Next arrow to proceed.

Note: When preparing for augmented glenoid components, be aware that the drilling axis is different from the reaming axis. The system accounts for this; the surgeon does not need to adjust for this mismatch.

	Implant	Implant Length (mm)	Drill to Use	Drill Flute Length (mm)	Overdrill Amount (mm)
ANATOMIC	Cage Glenoid	14.5	STD	19.3	4.8
	Cage Glenoid - 8° Augment	15.9	STD	19.3	3.4
	Laser Cage Glenoid	14.6	STD	19.3	4.7
	Laser Cage Glenoid - 8 degree Augment	15.9	STD	19.3	3.4
	Pegged Glenoid - Standard	11.7	STD	19.3	7.6
	Pegged Glenoid - 8° Posterior Augment	11.6	STD	19.3	7.7
	Pegged Glenoid - 16° Posterior Augment	12.2	STD	19.3	7.1
	Keeled	16	STD	19.3	3.3

Note: Not all instruments and implants are available in every market.

Note: GPS Ergo Center Drills are coated to indicate size, reflected in the cell color. These color indications are also present on the relevant GPS screens. The standard GPS Ergo Drill is gold coated.

Table 3

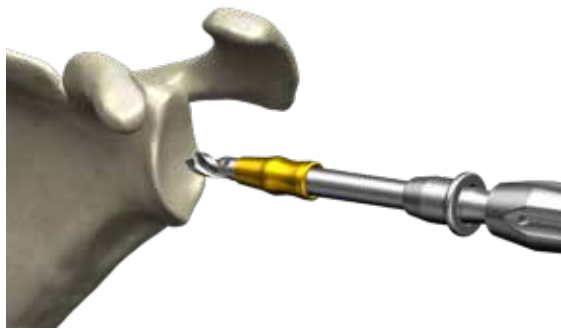

Figure 120

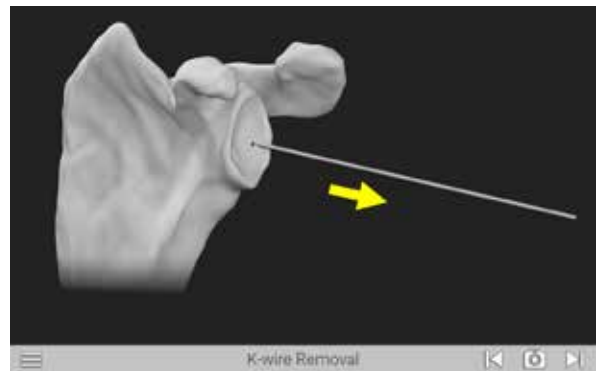

Figure 121

STEP 3: CENTER HOLE

CANNULATING BOTH REAMER AND CENTER DRILL:

In the case of a non-augment, when choosing to **cannulate both the center hole and reamer**, attach the **GPS Ergo Center Cage Drill** to the **Cannulated Driver** (Figure 120).

Be sure to use the correct drill based on the implant being used. Refer to the indicated size on screen or Table 3 above. Once the K-Wire is placed, guide the Center Drill and Driver assembly over the 3.2mm K-Wire.

In the case of an augment, when choosing to cannulate both the center hole and reamer, remove the K-Wire and repeat the K-Wire insertion from Step 1 to prepare the 3.2mm K-Wire for the center drill axis (different from reamer axis) (Figure 121). Then, use the cannulated GPS Ergo Center Cage Drill with the same color scheme.

CANNULATING REAMER AND PILOT TIP CENTER DRILL:

In the case of an augment, when choosing to cannulate the reamer but use the **Pilot Tip Center Drill**. Be sure to use the correct Pilot Tip Drill based on the implant being used.

Note: Do not perform cannulated reaming and then use a pilot tip center drill for cases utilizing a non-augmented Glenoid component.

DETAILED OPERATIVE TECHNIQUE

CANNULATED ANATOMIC SHOULDER



Figure 122



Figure 123

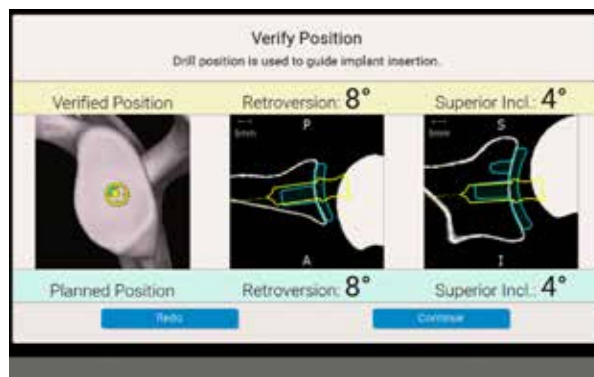

Figure 124

DRILLING

Drill the center cage hole for the Anatomic Glenoid using the on-screen guidance with the cross-hairs, as used in the previous steps. Once the drill is fully seated, the surgeon may advance to the next screen, **but do not take the drill out of the bone** (Figure 122).

Note: At any point in the procedure, the surgeon may use the probe to advance to the next screen by pressing the forward button twice while facing the camera.

VERIFY POSITION

With the drill still fully seated in the bone, hold the Drill in place over the drilled axis to capture the position of the planned implant. The system will adjust the original plan to where the drill was actually placed. The system will advance to the next step automatically, accurately recording the drill axis location and orientation (Figure 123).

A pop-up will appear showing the verified position of the drill vs. the planned position. If the surgeon would like to re-do the digitization, press Re-do. If the surgeon accepts the digitization, press Continue (Figure 124).

Note: Refer to the Ergo GPS Operative Technique for the full surgical technique.

DETAILED OPERATIVE TECHNIQUE

CANNULATED REVERSE SHOULDER



Figure 125

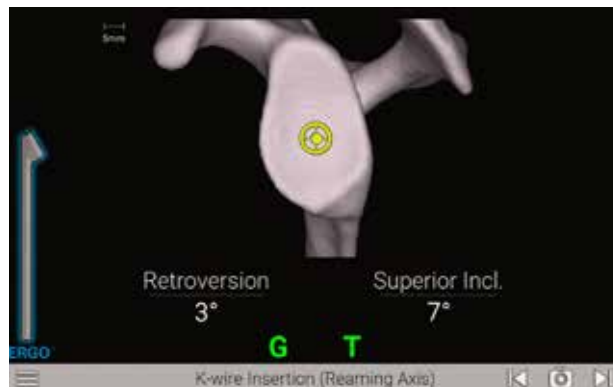



Figure 126

STEP 1: K-WIRE INSERTION FOR REAMING

For the cannulated workflow, attach the T-Tracker to the **GPS K-Wire Guide (531-55-26)** and insert a **Ergo 3.2mm K-Wire (321-52-08/09/10)** to guide the placement of the wire (Figure 125).

Follow the on-screen guidance to place the components according to the plan. The orientation is guided by the circular cross-hair indicator. When the target is perfectly aligned, the screen will display the cross-hair superimposed on the yellow dot (Figure 126).

-  For positioning of the Drill, the tip of the Drill is indicated by a yellow dot.
-  The planned position is indicated by a blue dot.

Follow the on-screen guidance to drill the center hole. Press the Next arrow to proceed.

Note: Avoid applying a bending force to the K-Wire Guide or using the K-Wire Guide to retract the humeral head as this may cause fracture of the 3.2mm K-Wire.

Note: The numbers shown for version and inclination are displayed according to the preoperative plan.

Note: The plan may not necessarily read 0° version and 0° inclination. The surgeon may deviate from this plan if desired. This screen includes an image of the orientation that is synchronized with the CT scan slices to visualize the cortices.

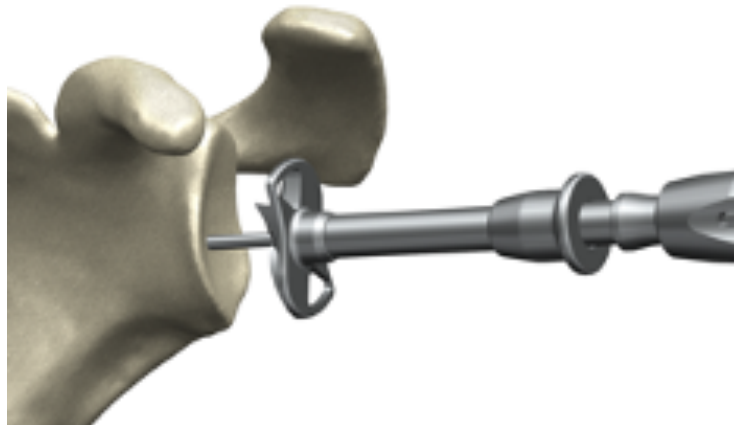

Figure 127

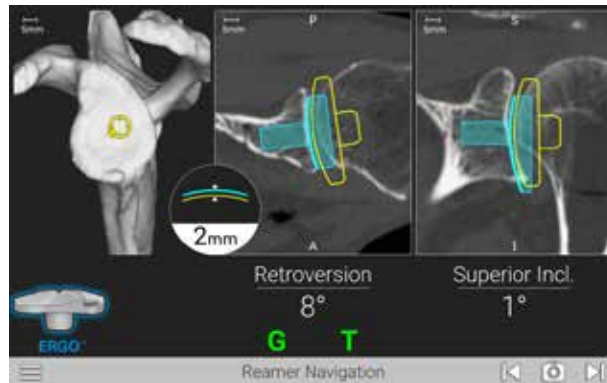

Figure 128

STEP 2: GLENOID REAMING

Select an **Ergo Reverse Reamer** per the Equinox Ergo surgical technique (OPTECH-000204) and attach it to the **GPS Ergo Cannulated Driver (531-55-01)** (Figure 127).

Follow the on-screen guidance to ream according to the plan. The reaming screen is guided in a similar fashion as the K-Wire Guide, with real-time feedback on the position of the reamer curvature relative to the planned depth (Figure 128).

Press the Next arrow to proceed.

Note: When preparing for augmented glenoid components, be aware that the drilling axis is different from the reaming axis. The system accounts for this; the surgeon does not need to adjust for this mismatch.

DETAILED OPERATIVE TECHNIQUE

CANNULATED REVERSE SHOULDER

	Implant	Implant Length (mm)	Drill to Use	Drill Flute Length (mm)	Overdrill Amount (mm)
REVERSE	Glenoid Baseplate - Standard	16.8	STD	19.3	2.5
	Glenoid Baseplate - 10° Superior Augment	18.3	STD	19.3	1
	Glenoid Baseplate - 8° Posterior Augment	16.8	STD	19.3	2.5
	Glenoid Baseplate - 10mm Extended Cage	26.8	EXT	25.3	-1.5*
	Glenoid Baseplate - Superior Posterior Augment	23.3	EXT	25.3	2
SMALL REVERSE	Small Glenoid Baseplate - Standard	13.1	SHORT	15.6	2.5
	Small Glenoid Baseplate - 10° Superior Augment	14.3	SHORT	15.6	1.3
	Small Glenoid Baseplate - 8° Posterior Augment	13.9	SHORT	15.6	1.7
	Small Glenoid Baseplate - 10mm Extended Cage	23.1	EXT	25.3	2.2
	Small Glenoid Baseplate - Superior Posterior Augment	18	STD	19.3	1.3

- Extended Drill
- Standard Drill
- Short Drill

Note: Not all instruments and implants are available in every market.

*Drill into the native glenoid bone first, and then add the graft and drill into the graft, as the drill is short.

Note: GPS Ergo Center Drills are coated to indicate size, reflected in the cell color. These color indications are also present on the relevant GPS screens. The short GPS Ergo drill is left uncoated, the standard GPS Ergo drill is gold coated, and the extended GPS Ergo drill is rose-gold coated.

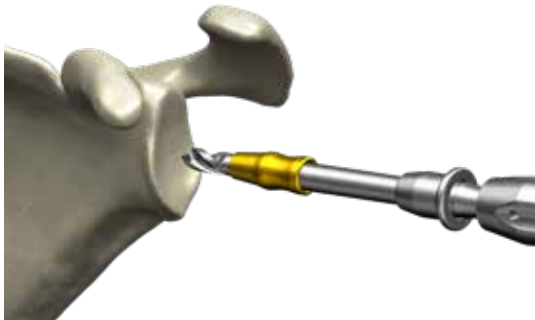

Figure 129

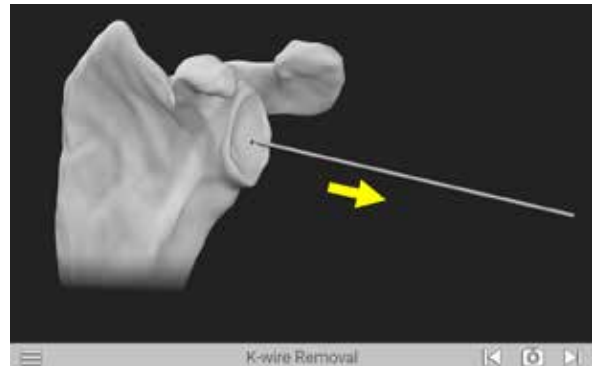

Figure 130

STEP 3: CENTER HOLE

After reaming, attach the T-Tracker to the GPS Driver.

Note: It is helpful to utilize a “tug test” both rotationally and vertically to ensure the tracker is properly fixated on the instrument and to ensure it does not move.

CANNULATING BOTH REAMER AND CENTER DRILL:

In the case of a non-augment, once K-Wire is placed, guide the Center Drill and Driver assembly over the 3.2mm K-Wire.

In the case of an augment, when choosing to **cannulate both the center hole and reamer**, remove the K-Wire (Figure 130) and repeat the **K-Wire Insertion** from **Step 1** to prepare the 3.2mm K-Wire for the center drill axis (different from reamer axis).

Then, use the cannulated GPS Ergo Center Cage Drills with the same color scheme.

CANNULATING REAMER AND PILOT TIP CENTER DRILL:

In the case of an augment, when choosing to cannulate the reamer but use the Pilot Tip Center Drill, remove the K-Wire (Figure 130). Be sure to use the correct Pilot Tip Drill based on the implant being used, refer to table above.

Note: Do not perform cannulated reaming and then use a pilot tip center drill for cases utilizing a non-augmented Glenoid component.

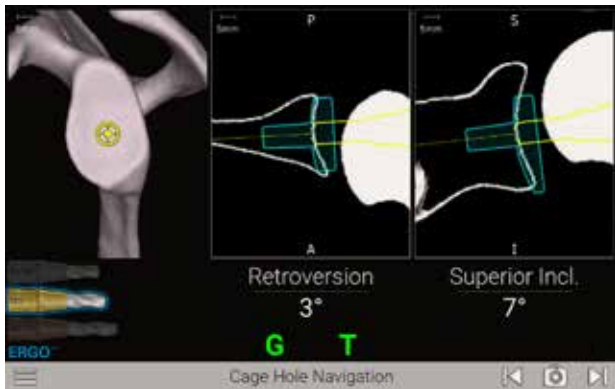

Figure 131



Figure 132

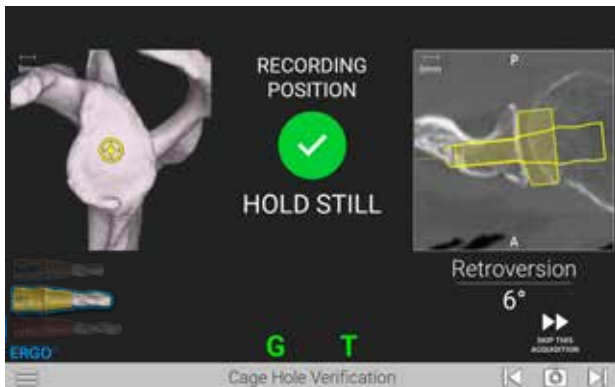

Figure 133

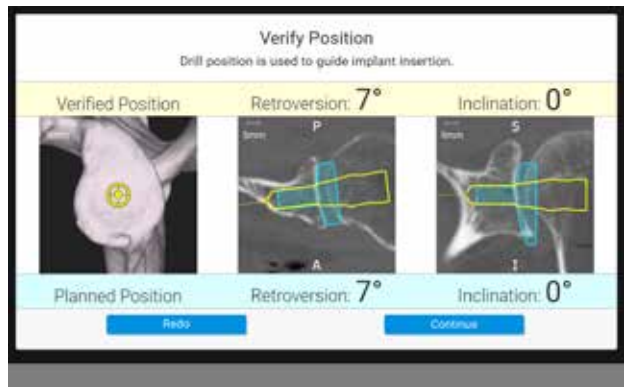

Figure 134

DRILLING

Drill the center cage hole for the Glenoid Implant (Figure 131). Once the drill is fully seated, the surgeon may advance to the next screen, but do not take the drill out of the bone (Figure 132).

Note: At any point in the procedure, the surgeon may use the probe to advance to the next screen by pressing the forward button twice while facing the camera.

VERIFY POSITION

With the drill still fully seated in the bone, hold the Drill in place over the drilled axis to capture the position of the planned implant. The system will adjust the original plan to where the drill was actually placed. The system will advance to the next step automatically, accurately recording the drill axis location and orientation (Figure 133).







A pop-up will appear showing the verified position of the drill vs. the planned position (Figure 134). If the surgeon would like to re-do the digitization, press Re-do. If the surgeon accepts the digitization, press Continue.

Note: Refer to the GPS Ergo Operative Technique for the full surgical technique.

CANNULATED INSTRUMENT LISTING

CATALOG NUMBER	PART DESCRIPTION	
KIT-501, KIT501C or KIT-501+ GPS Station V2+ or V2C		
I00025 or I00020	Main GPS Unit	
I00021	Power Supply	
J00010	Lower Mounting Arm	
J00012, J00020 or J00065	Upper Mounting Arm	
J00011	GPS Bedrail Clamp	
I00022	GPS Travel Case	
KIT-501V3 GPS Station V3		
I00030	Main GPS Unit	
I00031	Power Supply	
J00010	Lower Mounting Arm	
J00065	Upper Mounting Arm	
J00011	GPS Bedrail Clamp	
I00032	GPS Travel Case	
KIT-501T GPS Trackers		
A10003	GPS Probe	
A00203	GPS Probe V2	
A10005	GPS T-Tracker	
A00205	GPS T-Tracker V2	
A10006	GPS G-Tracker	
A00206	GPS G-Tracker V2	
<i>Note: F Tracker currently used for knee and ankle cases only</i>		
531Ergo_CAN GPS Shoulder Ergo Cannulated Mechanical Instruments		
531-07-05	Impactor Handle	
531-07-07	GPS Inserter Handle	
531-01-03	Coracoid Block Left	
531-01-04	Coracoid Block Right	
531-55-01	Ergo GPS Cannulated Driver	
531-55-09	Ergo GPS 3.2mm Drill Guide	

CANNULATED INSTRUMENT LISTING

CATALOG NUMBER	PART DESCRIPTION	
531-55-63: Short (silver) 531-55-65: STD (gold) 531-55-67: EXT (rose gold)	Ergo GPS Cannulated Center Drill Bits	
531-55-62: Short (silver) 531-55-64: STD (gold) 531-55-66: EXT (rose gold)	Ergo GPS Pilot-tip Center Drill Bits	
521-78-11	Pin Driver, Short Low Profile	
531-55-26	Ergo GPS K-Wire Guide	
GPS Shoulder Disposables		
531-78-20	Disposable Hex Pins Kit	
531-55-88	Ergo Disposable Reverse Drill Kit	
A10012 A10032	GPS V2+ or V2C Disposable Kit GPS V3 Disposable Kit <i>Includes sterile drape, batteries and cleaning wipe</i>	

The Shoulder Planning App and GPS are manufactured by Blue Ortho SAS, an Advita Ortho subsidiary, and distributed by Advita Ortho, LLC.

For additional device information, refer to the manufacturer's Instructions for Use for information including, but not limited to, a device description, indications, contraindications, precautions and warnings. For further product information, please contact Customer Service, Advita Ortho, LLC. 2320 NW 66th Court, Gainesville, Florida 32653-1630, USA. (833) 4-ADVITA.

Blue Ortho, as the manufacturer of this device, does not practice medicine and is not responsible for recommending the appropriate surgical technique for use on a particular patient. Because this information does not purport to constitute any diagnostic or therapeutic statement with regard to any individual medical case, each patient must be examined and advised individually, and this document does not replace the need for such examination and/or advice in whole or in part. These guidelines are intended to be solely informational, and each surgeon must evaluate the appropriateness of these guidelines based on his or her personal medical training and experience. Prior to use of this system, the surgeon should refer to the product package insert for information including, but not limited to, comprehensive warnings, precautions, indications for use, contraindications and adverse effects.

The products discussed herein may be available under different trademarks in different countries. All copyrights, and pending and registered trademarks, are property of Blue Ortho & Advita Ortho, LLC. **This material is intended for the sole use and benefit of the Advita Ortho sales force and physicians; it is not intended for laypersons.** It should not be redistributed, duplicated or disclosed without the express written consent of Advita Ortho, LLC. ©2025 Advita Ortho, LLC. OPTECH-000181/A 102225



CE Mark is not valid unless there is a CE Mark on the product label.



GLOBAL HEADQUARTERS
2320 NW 66TH COURT
GAINESVILLE, FL 32653-1630 USA
(833) 4-ADVITA
advita.com